

MINUTES OF THE REGULAR MEETING OF THE
BOARD OF DIRECTORS OF THE
VISTA IRRIGATION DISTRICT

May 11, 2016

A Regular Meeting of the Board of Directors of Vista Irrigation District was held on Wednesday, May 11, 2016, at the offices of the District, 1391 Engineer Street, Vista, California.

1. CALL TO ORDER

President Vásquez called the meeting to order at 8:30 a.m.

2. ROLL CALL

Directors present: Miller, Vásquez, Dorey, Reznicek, and MacKenzie.

Directors absent: None.

Staff present: Roy Coox, General Manager; Lisa Soto, Secretary of the Board; Eldon Boone, Assistant General Manager; Don Smith, Director of Water Resources; Brian Smith, Director of Engineering; Brett Hodgkiss, Administrative Services Manager; Frank Wolinski, Operations and Field Services Manager; Phil Zamora, Human Resources Manager; Brent Reyes, Water Conservation Specialist; Brian Fisher, Information Technology Supervisor; Al Ducusin, Engineering Department Manager; Randy Whitmann, Engineering Project Manager; Ramae Ogilvie, Administrative Office Assistant; Marlene Kelleher, Finance Manager; and Marian Schmidt, Administrative Assistant. Back-up General Counsel Jeremy Jungreis was also present.

Other attendees: Winners of the Poster, Scholarship, and California-Friendly Landscape Contests and their respective family members; and Mr. Chris Palmer, the Southern California Field Representative for the California Special Districts Association.

3. PLEDGE OF ALLEGIANCE

Director Vasquez led the pledge of allegiance.

4. APPROVAL OF AGENDA

16-05-46	<i>Upon motion by Director MacKenzie, seconded by Director Miller and unanimously carried (5 ayes: Miller, Vásquez, Dorey, Reznicek, and MacKenzie), the Board of Directors approved the agenda as presented.</i>
----------	---

5. PUBLIC COMMENT TIME

No public comments were presented on items not appearing on the agenda.

6. CONSENT CALENDAR

16-05-47	<i>Upon motion by Director Miller, seconded by Director MacKenzie and unanimously carried (5 ayes: Miller, Vásquez, Dorey, Reznicek, and MacKenzie), the Board of Directors approved the Consent Calendar, including Resolution No. 16-11 approving disbursements.</i>
----------	--

A. Treasurer's Report as of March 31, 2016

The Board noted and filed the Treasurer's Report as of March 31, 2016 which was provided for informational purposes.

B. Microsoft Software Licensing Agreement

See staff report attached hereto. Staff recommended and the Board authorized the General Manager to enter into a Microsoft Enterprise Agreement (MEA) with SoftwareOne for the three year period ending May 31, 2019.

C. Well Field Maintenance Services Agreement

See staff report attached hereto. Staff recommended and the Board authorized the General Manager to enter into an agreement with Hidden Valley Pump Systems, Inc. to provide as-needed services on the Warner Ranch to maintain wells and well pumps.

D. Annual Contract for Material Transport Services

See staff report attached hereto. Staff recommended and the Board authorized the General Manager to extend the existing contract with Leon Perrault Trucking to provide additional transport services and assorted material for District jobs.

E. Annual Contract Traffic Control Services

See staff report attached hereto. Staff recommended and the Board accepted the bid results and authorized the General Manager to enter into a contractual service agreement with Cecilia's Safety Services, Inc. to provide traffic control services for District jobs.

F. Annual Contract for Patch Paving Services

See staff report attached hereto. Staff recommended and the Board authorized the General Manager to extend the existing contract with Joe's Paving, Inc. to perform patch paving on excavations under 1,500 square feet.

G. Valve Operating System

See staff report attached hereto. Staff recommended and the Board approved the purchase of an automated valve operating system.

H. Notice of Fees Document and Imported Water Entitlement

See staff report attached hereto. Staff recommended and the Board approved the cancellation of the recorded document titled Notice of Fees Due and Payable Upon Application for Water Service

(portion of OD-3R) and approved the Imported Water Entitlement document for a parcel consisting of approximately 1.24 gross acres owned by Lindagreen, L.L.C., located at 2133 North Santa Fe Avenue, Vista, and directed the Secretary to record the documents with the County Recorder (APN 159-240-32; DIV NO 1).

I. Minutes of the Water Sustainability Committee meeting on April 28, 2016

The Board noted and filed the minutes of the Water Sustainability Committee meeting on April 28, 2016, which were provided for informational purposes.

J. Minutes of Board of Directors meeting on April 20, 2016

The minutes of April 20, 2016 were approved as presented.

K. Resolution ratifying check disbursements

RESOLUTION NO. 16-11

BE IT RESOLVED, that the Board of Directors of Vista Irrigation District does hereby approve checks numbered 52949 through 53116 drawn on Union Bank totaling \$592,052.16.

FURTHER RESOLVED that the Board of Directors does hereby authorize the execution of the checks by the appropriate officers of the District.

PASSED AND ADOPTED unanimously by a roll call vote of the Board of Directors of Vista Irrigation District this 11th day of May 2016.

Brian Fisher left the meeting at this time.

7. PRESENTATION OF AWARDS TO WINNERS OF THE WATER AWARENESS POSTER CONTEST

See staff report attached hereto.

General Manager Roy Coox said that the District was pleased to welcome and recognize the winners of this year's Fourth Grade Water Awareness Poster Contest. Water Conservation Specialist Brent Reyes stated that this was the District's 24th year of participation in the contest, adding that this year's theme was "Be Water Smart". He noted that the District received 262 entries this year, with the top three entries selected by a committee of randomly chosen VID employees. Mr. Reyes said that the winners were all present in the audience, and he proceeded to call them up one by one so that President Vásquez could present them with their awards.

President Vásquez awarded the third place prize of \$25 to Ariana Barragan of Joli Ann Leichtag Elementary School, the second place prize of \$50 to Rebecca Gutierrez of Tri-City Christian School, and first place prize to Lanea Rico of Mission Meadows Elementary School. The Board joined President Vásquez and staff in congratulating the children and thanking all of the contest participants. The winners and their families left the meeting at this time.

8. SCHOLARSHIP CONTEST AWARD PRESENTATIONS

See staff report attached hereto.

Administrative Services Manager Brett Hodgkiss presented an overview of the VID Scholarship Contest and its requirements. Mr. Hodgkiss stated that six applications were submitted by the deadline, and the applications were reviewed by the Public Affairs Committee. Mr. Hodgkiss said that the Committee selected three applicants to receive awards—one winner and two runners-up. President Vásquez commented that judging the VID Scholarship Contest is one of his favorite duties as Chair of the Public Affairs Committee. Director Reznicek, a member of the Public Affairs Committee, said that he and President Vasquez were very pleased with all of the submissions, and were particularly impressed with the top three.

President Vásquez presented two runners-up awards of \$750 each Marcy Faison of North County Trade Tech High School and to Randy Robbins of Rancho Buena Vista High School. President Vásquez awarded \$1,500 to Nicholas Smith of Tri-City Christian School as the winner of the VID Scholarship contest. The Board joined President Vásquez and staff in congratulating the winners and commending all of the scholarship applicants, and wishing them all the best in the future.

Two of the students, Marcy Faison and Nicholas Smith, presented the Board with thank you notes (attached hereto as Exhibit A). All three students and their families left the meeting at this time.

9. 2016 CALIFORNIA-FRIENDLY LANDSCAPE CONTEST AWARD PRESENTATION

See staff report attached hereto.

Mr. Reyes said that he did not envy the job of the Water Sustainability Committee in judging this year's contest, as there were some really beautiful entries this year. Mr. Reyes said that the Committee selected two entries that best met the contest criteria. President Vásquez awarded Tamara Dias a framed certificate as an honorable mention in the contest. Mr. Reyes said that Ms. Dias replaced 5,000 square feet of lawn from her front property with a beautiful colorful California-Friendly landscape, and reduced her water use by 67 percent compared to the previous year. President Vásquez awarded the winners in the contest, John and Marcia Rea, a \$250 gift certificate and an engraved plaque. Mr. Reyes said that the Rea's California-Friendly landscape transformation was quite remarkable. They too replaced their lawn with landscape materials that are beautiful, low maintenance, and low water use.

Director Dorey said that reviewing all of the submissions was a daunting task because there were so many submissions this year. He noted that he and fellow Committee member Director Reznicek came to the same independent conclusions, and agreed very quickly on the winning entry and the honorable mention. Director Reznicek agreed. The Board congratulated the contestants and thanked them for their participation in the contest and for their water saving efforts. Mr. Coox added that staff will be sending letters of appreciation along with some water conservation materials to all of the contest participants to thank them for their time and effort in submitting an application.

The Landscape Contest winners left the meeting at this time, as did Mr. Reyes.

10. RECOGNITION IN SPECIAL DISTRICT GOVERNANCE

See staff report attached hereto.

Mr. Coox said that Directors Reznicek and Miller have both earned their individual Recognitions in Special District Governance, and now that all five members of the Board have done so, the District has earned its Gold Recognition in Special District Governance. Mr. Coox introduced Mr. Chris Palmer, the Southern California Field Representative for the California Special Districts Association, who was in

attendance to present these Recognitions to Directors Miller and Reznicek, as well as to the Board. Mr. Palmer said that the District is one of only four (out of over 2,000 special districts in the State of California) that has earned the level of Gold Recognition. Director MacKenzie added that all four of the districts with Gold Recognition happen to be from the Southern Region. Mr. Palmer congratulated the Board on its achievement, adding that he can think of no better way for a District to demonstrate its commitment and dedication to providing the best possible service to the communities they serve. Mr. Palmer presented the awards, and photos were taken. The Board thanked Mr. Palmer for coming, and Mr. Palmer left the meeting at this time.

11. DIVISION REPORTS

See staff report attached hereto.

Operations and Field Services Manager Frank Wolinski updated the Board briefly regarding the draining of HP Reservoir noted in the Division Reports. He also updated the Board regarding an upcoming project to replace approximately 1,000 linear feet of pipeline (6" steel and some Nipponite) on Mar Vista Drive. He stated that the project is expected to take from six to eight weeks to complete.

Director of Engineering Brian Smith updated the Board regarding the exchange agreement with Vallecitos Municipal Water District for the accounts on Fairview Drive in Vista. Mr. Smith stated that a notice will be mailed to the affected residents informing them of the plans to install new laterals for these accounts which will result in these customers receiving their water directly from VID in the future.

Mr. Hodgkiss provided clarification regarding the District's current 12 percent conservation goal, stating that the goal is cumulative to when the mandatory restrictions went into place in June 2015. He noted that the District's goal was reduced in March 2016 from 20 percent to 12 percent. Mr. Hodgkiss said that the State regulations are in the process of being changed again to be extended through January 2017. Mr. Hodgkiss commented that the 2013 baseline for comparison has not changed. Mr. Hodgkiss clarified that, despite the recent report in the newspaper that the District did not meet its 12 percent conservation target because the District achieved 11.6 percent conservation for the month in question, the District was in compliance by being well within its cumulative goal.

Director of Water Resources Don Smith updated the Board regarding the meeting he attended hosted by the Department of Water Resources (DWR) to discuss groundwater management practices and possible collaboration and/or coordination regarding elements of the Sustainable Groundwater Management Act (SGMA). He commented that the presentation was particularly focused on grant opportunities, and it was laid out in such a way that it would have been difficult for a layperson to understand. Mr. Smith noted that there were tribal representatives from all over San Diego County as well as Riverside County and Coachella. Mr. Smith noted that the tribal entities are somewhat concerned about their involvement with the SGMA, and in what ways they may or may not participate. Back-up General Counsel Jeremy Jungreis provided brief clarification about some new statutory requirements for SGMA and the Groundwater Sustainability Plans as they pertain to tribal concerns.

12. DISTRICT WEBSITE

See staff report attached hereto.

Mr. Hodgkiss provided an overview of the website project thus far, recalling the feedback and direction given by the Board in January. Mr. Hodgkiss provided a live demonstration of the site, to which content has been added for testing by staff. Mr. Hodgkiss explained that most of what is visible on the site is flexible and easily changeable by staff. Mr. Hodgkiss said that staff plans to hire a professional

photographer to photograph different sites and aspects of the District for the carousel and for other uses on the website. The Board asked about some live searches on the site, which Mr. Hodgkiss conducted to demonstrate the site's functionality. The Board asked questions and received clarification as needed. The Board suggested creating a separate sub-page for Board committees which will provide a description of each committee, inform the customers that District committees meet on an as-needed basis, provide a roster of Board committee members, and indicate the chair of each committee.

There was a brief discussion about the location of District's Ticket Policy on the website, and whether or not the information is readily available (as required by law). Director Dorey said that a search of the site for "Ticket Policy" easily yielded the appropriate result. The Board was satisfied with the accessibility of this policy. There was also a discussion regarding the ability to return to the District's homepage from any page on the site. It was pointed out that, as with most websites, clicking on the VID logo (which appears on every page) will always return the user to the homepage. It was suggested that this shortcut somehow be made obvious to the end-user who may not know about it. Director MacKenzie complimented the placement of the District's phone number at the top of every page on the site.

The Board was complimentary of the progress made on the website, and thanked Mr. Hodgkiss for his work on the site. Mr. Hodgkiss stated that he hopes to go live with the site sometime in June. He added that when the new site launches, it will be with a new URL (vidwater.org), and all VID email addresses will change at that time as well.

Ramae Ogilvie and Brett Hodgkiss left the meeting at the conclusion of this discussion.

13. HP RESERVOIR STRUCTURAL EVALUATION

See staff report attached hereto.

Engineering Project Manager Randy Whitmann presented an overview of the item, stating that the HP Reservoir is a five million gallon, pre-stressed concrete tank, which was constructed in the early 1960s. It is located near the end of Edgehill Road and it serves one of the highest pressure zones (elevations) in the District's service area. Recently, exterior concrete spalling was found near the base of the tank exposing the steel pre-stressing cables, with some detached from the wall and laying on the ground. Mr. Whitmann said that after a site visit with consultant Richard Brady and his structural engineer, Max Dykmans, it was recommended that the tank be drained and scheduled for immediate evaluation and repair. Mr. Whitmann said that at this time, staff is seeking authorization to move forward with a structural analysis of the tank to determine the extent of the necessary upgrades and repairs to the tank. Mr. Whitmann said that staff will then compare the cost of repairing and upgrading the tank to the cost of constructing a new reservoir.

Director MacKenzie asked if the District's master plan has any indication of a need to expand the capacity of this tank. Mr. Whitmann responded that the District's water use has decreased since the master plan was last updated in 2000. He said that the master plan is going to be updated in the near future, but he believes that projections will indicate no need to expand the capacity of this tank. The Board discussed whether rebuilding the tank would be more cost effective than repairing it. It was acknowledged that staff's proposed assessment of the tank will better inform the answer to this question. Director Dorey pointed out the importance of the District's reservoirs for fire protection, and if one reservoir is incapacitated, as is the case with HP reservoir, this is an urgent matter to be addressed. Mr. Smith stated that it take approximately 90 days to complete the structural evaluation and provide the District with a full report.

16-05-48 *Upon motion by Director Miller, seconded by Director Reznicek and unanimously carried (5 ayes: Miller, Vásquez, Dorey, Reznicek, and MacKenzie), the Board of Directors authorized the General Manager to enter into an Agreement for Professional Services with Richard Brady & Associates for the HP Reservoir Structural Evaluation for a cost not to exceed \$75,000.*

A brief break was taken from 10:17 a.m. to 10:27 a.m.

14. MAIN REPLACEMENT PROGRAM UPDATE

See staff report attached hereto.

Mr. Coox said that the District's proactive main replacement program was put into place by the Board many years ago, and staff is quite proud of it. Mr. Brian Smith presented an overview of the program and a snapshot of where the District is with it. Mr. Smith said that the District's main priority is to replace the approximately 12 miles of Nipponite pipe still in service in the District. Mr. Smith said that the main focus is to replace the six and eight inch Nipponite, which is the most prone to failure. Mr. Smith said that in this year's budget, staff will be proposing an increase in funding for the program. With the increased funding, a consultant can be brought on board to do some additional design work in order to accelerate replacement of the Nipponite pipe. Mr. Smith said that currently, through the use of in-house staff and construction crews, the District is able to replace about two miles of pipe each year. Mr. Smith said that as part of the request for proposals for the master plan update this year, staff has asked consultants to include in their proposal an evaluation of the District's main replacement program in order to help fine-tune the way the replacements are being prioritized. The Board thanked staff for the report.

15. GRANT OF NONEXCLUSIVE EASEMENT

Mr. Brian Smith said that acceptance of this Grant of Nonexclusive Easement is the first step in Shea Homes' (Shea) project to relocate a portion of the Vista Flume to the public right-of-way as part of its development of a 179 lot residential subdivision. Mr. Smith said that most of the relocation will be in the City of Escondido's street rights-of-way, but a small portion of it will be outside the right-of-way, so the District will need this easement from Shea for that portion of the flume. Mr. Smith said that the next steps will be for the Board to consider approval of project and the reimbursement agreement with Shea.

16-05-49 *Upon motion by Director Miller, seconded by Director MacKenzie and unanimously carried (5 ayes: Miller, Vásquez, Dorey, Reznicek, and MacKenzie), the Board of Directors accepted Grant of Nonexclusive Easement No. FS38 (Modified) for a 30-foot easement over property owned by Shea Homes Limited Partnership (Shea) located north of Vista Verde Dr., Escondido (LN-2015-003, APN 224-100-12, 57, 58, 59 & 60).*

16. REVISIONS TO COMPENSATION SCHEDULE

Mr. Coox said that this item is in response to some new regulations which require public agencies to take formal action to approve compensation schedules before they can be considered valid by the Public Employees Retirement System (PERS). Mr. Coox said that the Board previously approved the District's Compensation Schedule, and this item is to approve revisions to the schedule to remain in compliance with state pension law. Mr. Boone reviewed three new job titles which have been added to the schedule approved by the Board in December 2015. The new positions include Water Resources Engineer, Human Resources Office Assistant, and Administrative Office Assistant. Mr. Boone noted that these are not new positions per se, but rather they are new titles based on

revised job duties following the separation of three employees from the District. Mr. Boone said that effectively, the Water Resources Engineer position replaces the Water Resources Manager, the Human Resources Office Assistant replaces the Human Resources Specialist, and the Administrative Office Assistant replaces the Administrative Secretary. Mr. Boone said that by reorganizing in this way, the District can improve operational efficiencies and create more opportunities for internal promotional advancement.

16-05-50 *Upon motion by Director Dorey, seconded by Director MacKenzie, the Board of Directors adopted Resolution 16-12 approving changes to the 2016 Compensation Schedule for all District employees to facilitate CalPERS reporting requirements under state pension law, by the following roll-call vote:*

AYES: Directors Miller, Dorey, Reznicek, MacKenzie, and Vásquez
NOES: None
ABSTAIN: None
ABSENT: None

A copy of Resolution 16-12 is on file in the official Resolution Book of the District.

17. MATTERS PERTAINING TO THE ACTIVITIES OF THE SAN DIEGO COUNTY WATER AUTHORITY

See staff report attached hereto.

Director Miller reported that the Water Authority received the 2016 “Excellence in the Construction Project Award” from the United States Society on Dams for its San Vicente dam raise project. Director Miller said that the final thing to be done in the San Vicente dam raise project is for the Water Authority Board to approve the Notice of Completion on the bypass pipeline.

Director Miller reported that the maintenance costs for the Olivenhain dam have been calculated to be about \$300,000 per year, and these costs will be added to the agreements going forward. Director Miller reported that Lakes Shasta and Oroville are both at 90-95 percent of capacity, and Folsom Lake is also near capacity. He added that while the snow pack is less than was expected, it is also in fairly good condition, but the run-off is occurring rapidly.

Director Miller reported that the Metropolitan Water District (MWD) did not approve the fee for treated water that was a topic of discussion in April. Director Miller stated that he would be out of town for the next Water Authority meeting, and he has tendered his proxy to Gary Arant of Valley Center Municipal Water District. He said if any of his fellow Board members would like to attend and observe the meeting in his absence, to feel free.

18. REPORTS ON MEETINGS AND EVENTS ATTENDED BY DIRECTORS, AND AUTHORIZATION FOR DIRECTOR ATTENDANCE AT UPCOMING MEETINGS AND EVENTS

See staff report attached hereto.

Director Miller reported on his attendance at the recent ACWA Conference where he attended Mr. Jungreis’ presentation about the Sustainable Groundwater Management Act (SGMA) and how overlapping jurisdictions are being resolved. Director Miller reported on a presentation he attended by the

California Independent System Operator (ISO) about new regulatory programs to address statewide greenhouse emissions reduction goals, and the increased amounts of renewable energy coming into the mix which has created an imbalance in the system.

Director Dorey reported on his attendance at the recent ACWA Conference where he noted that SGMA issues were very much at the forefront of discussion at this conference. Director Dorey said he attended a session regarding AB 52. This new provision of CEQA requires water agencies, when acting as lead agencies, to enter into consultation with requesting tribes prior to the release of a negative declaration or an Environmental Impact Report (EIR).

Director Dorey extended his thanks to Water Resources Office Assistant Jessica Sherwood for backing him up on the San Luis Rey Watershed Council, and for making sure he receives the information for the occasional meeting he may miss due to a schedule conflict.

Director MacKenzie reported on her attendance at the recent ACWA Conference where she sat in on meetings of the Joint Powers Insurance Authority (JPIA) Board and Executive Committee. She noted that a great deal of time was devoted to a request made by Kevin Hunt, the General Manager of the Central Basin Water District, for his agency's reinstatement of coverage with JPIA. His agency's request was denied.

Director MacKenzie reported on her attendance at a meeting of the ACWA Local Government Committee where the proposed amendment to Article 10 of the California Constitution was discussed. This amendment, if passed, would address two issues that have come out of Prop 218; one is limitations on the ability to adopt tiered rates, and the other is restrictions on the ability to collect a storm water fee. The amendment would also allow the establishment of lifeline rates for low income households. Director MacKenzie said that after polling netted a mostly negative response, ACWA has removed itself from the coalition promoting the amendment. She added that the issue will likely be bifurcated to tackle storm water separately.

Directors MacKenzie and Dorey indicated an interest in attending the San Diego Chapter CSDA Video Awards Ceremony the following night at Helix Water District to unveil the winning videos in the contest to educate the public about *What's So Special About Special Districts?*

Director Miller requested to attend the CSDA Conference in October and the Colorado River Users Conference in December. President Vásquez requested to attend the meeting of the Council of Water Utilities (COWU) the following week.

16-05-51	<i>Upon motion by Director Miller, seconded by Director MacKenzie and unanimously carried (5 ayes: Miller, Vásquez, Dorey, Reznicek, and MacKenzie), the Board of Directors authorized the following attendances: Directors MacKenzie and Dorey to attend the San Diego Chapter CSDA Video Awards Ceremony on May 12 in La Mesa; Director Miller to attend the CSDA Conference in October in San Diego and the Colorado River Users Conference in December in Las Vegas; and President Vásquez to attend the COWU meeting on May 17.</i>
----------	--

19. ITEMS FOR FUTURE AGENDAS AND/OR PRESS RELEASES

See staff report attached hereto.

None were presented.

20. COMMENTS BY DIRECTORS

Director MacKenzie suggested changes to the landscape contest to standardize the photos to be included with the applications, such as taking “before” and “after” photos from the same perspective. Mr. Boone responded that people don’t always know prior to embarking on a landscape renovation project that they will eventually enter their project in this contest; therefore, “before” photos aren’t always included. Mr. Hodgkiss said that he and his staff are planning to make suggestions to the Regional Contest Committee to address some of the issues regarding how the application packets are submitted and the photographs that are included.

President Vásquez reported on some water related news articles regarding the State mandated conservation plan and the Coastwatchers’ report on suffering creek levels due to lack of rain.

21. COMMENTS BY GENERAL COUNSEL

None were presented.

22. COMMENTS BY GENERAL MANAGER

Mr. Coox informed the Board that due to recent rain and pumping, the water level at Lake Henshaw has increased by 100 acre feet, peaking at just over 5,800 acre feet. Mr. Coox said that the District is entering into the season for releasing water from the lake, so this level will soon begin to diminish.

Mr. Coox said that with the end of the school year approaching, the time for senior scholarship presentations is coming up at the local high schools. The District has one winner at Rancho Buena Vista High School (RBV), and if the Public Affairs Committee members or the Board President would like to make the presentation, to let staff know so that the necessary arrangements can be made. The awards ceremony at RBV will be the evening of May 25.

Mr. Coox said that the District has received some public records requests regarding Board reimbursements and expenditures, which have prompted a discussion among staff regarding the Quarterly Board Expense Report. Mr. Coox said that this report is not to be confused with the AB 1542 report which is prepared annually per Government Code. The Quarterly Board Expense report is not a legal requirement, and it appears to be something the Board requested approximately 20 years ago. Mr. Coox showed the Board an example of the Quarterly Expense Report, and asked if the Board would like staff to continue to provide this report, which is labor intensive to produce, and could be considered redundant to the AB 1542 report. The Board discussed the matter briefly and requested that this matter be agendized for future Board consideration.

At this time, everyone present in the audience left the Boardroom except for Don Smith. Director Reznicek also left the meeting at this time.

23. CLOSED SESSION FOR CONFERENCE WITH LEGAL COUNSEL

President Vásquez adjourned the meeting to closed session at 11:51 a.m. for a conference with legal counsel per Paragraph (1) of subdivision (d) of Government Code section 54956.9 to discuss the following pending litigation:

- A. San Luis Rey Indian Water Rights Litigation (Settlement)

The meeting reconvened in open session at 12:10 p.m. President Vásquez declared that no reportable action had been taken.

At this time, Assistant General Manager Eldon Boone requested that Agenda Item 22 be reopened.

22. COMMENTS BY GENERAL MANAGER

Mr. Boone reported that Water Authority staff is recommending to the Water Authority Board to increase rates next year for treated and untreated water by six percent. Mr. Boone said the Water Authority is expecting the settlement with MWD to be in place by the following year, at which time rates will decrease by ten percent.

Mr. Boone said that on the previous Monday, Governor Brown issued an executive order to make conservation a way of life in California. In response, the State Water Board is preparing new mandates. The comment period for the new mandates ends this Friday, May 13, and the Water Authority is compiling all of the comments by its member agencies to be submitted as a group.

Mr. Boone congratulated Director Miller for his recent appointment as Chair of the Engineering and Operations Committee, effective July 1, 2016. The Board also congratulated Director Miller.

24. ADJOURNMENT

There being no further business to come before the Board, President Vásquez adjourned the meeting at 12:16 p.m.

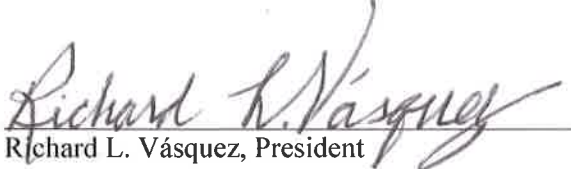
Richard L. Vásquez, President

ATTEST:



Lisa R. Soto, Secretary
Board of Directors
VISTA IRRIGATION DISTRICT



STAFF REPORT

Agenda Item: 6.A

Board Meeting Date:	May 11, 2016
Prepared By:	Farrokh Shahamiri
Reviewed By:	Marlene Kelleher
Approved By:	Eldon Boone

SUBJECT: TREASURER’S REPORT AS OF MARCH 31, 2016

RECOMMENDATION: Informational report concerning the investments of the District.

SUMMARY: Attached for review by the Board of Directors is the Treasurer’s Report as of March 31, 2016. The report is formatted to provide information as required by the California Government Code and the Vista Irrigation District Investment Policy. The Treasurer’s Report contains both an investment summary and a detailed security listing. Also attached is a five-year cash flow forecast, which indicates the District’s investments are sufficiently liquid to meet anticipated cash flow needs.

DETAILED REPORT: Activity for the quarter included deposits and withdrawals from the District’s cash and cash equivalent accounts: checking, California Asset Management Program (CAMP), and Local Agency Investment Fund (LAIF). During the quarter \$6 million of Treasury bills matured and \$6 million of new Treasury bills were purchased.

As of March 31, 2016, the net unrealized gain on the portfolio was as follows:

	<u>Unrealized Gain</u>
Treasury Bills	\$46,447
LAIF	<u>2,468</u>
Net Unrealized Gain	<u>\$48,915</u>

All investment transactions have been made in accordance with the District’s Investment Policy and market value information is obtained from the Wall Street Journal.

The following is a five-year summary of the District’s investment portfolio:

	<u>3/31/12</u>	<u>3/31/13</u>	<u>3/31/14</u>	<u>3/31/15</u>	<u>3/31/16</u>
Total Portfolio	\$22,507,033	\$26,318,694	\$32,863,186	\$36,475,959	\$31,288,682
Unrealized Gain	\$15,455	\$26,882	\$15,744	\$18,524	\$48,915
Weighted Average Maturity	100 Days	85 Days	68 Days	89 Days	123 Days
Portfolio Interest Rate	0.21%	0.19%	0.15%	0.17%	0.48%

ATTACHMENTS: Treasurer’s Report
Securities Detail
Cash Flow Projection

Vista Irrigation District
TREASURER'S REPORT
March 31, 2016

<u>Category</u>	<u>Maturity Value</u>	<u>Percentage Permitted by Board Policy</u>	<u>Actual Percentage</u>	<u>Weighted Average Maturity (in Days)</u>	<u>Current Interest Rate</u>
Cash and Cash Equivalents					
Checking/Petty Cash	\$ 362,673	n/a	1.2%	0	0.00%
California Asset Management Program	260,096	40%	0.8%	1	0.46%
Local Agency Investment Fund	11,165,913	40%	35.7%	1	0.51%
	<u>11,788,682</u>		<u>37.7%</u>	<u>1</u>	<u>0.49%</u>
Securities					
U.S. Treasury	19,500,000	100%	62.3%	196	0.47%
Total Portfolio	<u>\$ 31,288,682</u>		<u>100.0%</u>	<u>123</u>	<u>0.48%</u>

Notes:

- ◆ This report excludes accrued interest and employee flexible spending accounts.
- ◆ California Asset Management Program (CAMP) is a California Joint Powers Authority (JPA) established to provide California public agencies with professional investment services. The CAMP pool is a permitted investment for all local agencies under California Government Code Section 53601(p). The market valuation is provided by PFM Asset Management LLC.
- ◆ Local Agency Investment Fund (LAIF) is a pool of funds invested for California governmental agencies and is managed by the State Treasurer's Office of the State of California. The market valuation is provided by the State Treasurer's Office.
- ◆ The above portfolio is in full compliance with the District's Investment Policy.
- ◆ The District's investment portfolio is adequate to meet the District's cash flow requirements for the next six months.

Vista Irrigation District
SECURITIES DETAIL
March 31, 2016

Issuer	Investment Type	Interest Rate	Maturity Date	Days to Maturity	Maturity Value	Cost	Market Value	Unrealized Gain/(Loss)
U.S. Treasury	Treasury Bill	0.250%	04/28/16	28	\$ 1,500,000	\$ 1,496,284	\$ 1,499,822	\$ 3,537
U.S. Treasury	Treasury Bill	0.260%	05/26/16	56	1,500,000	1,496,133	1,499,724	3,591
U.S. Treasury	Treasury Bill	0.295%	06/23/16	84	1,500,000	1,495,602	1,499,316	3,715
U.S. Treasury	Treasury Bill	0.336%	07/21/16	112	1,500,000	1,494,995	1,498,780	3,785
U.S. Treasury	Treasury Bill	0.418%	08/18/16	140	1,500,000	1,493,782	1,498,073	4,291
U.S. Treasury	Treasury Bill	0.449%	09/15/16	168	1,500,000	1,493,327	1,497,735	4,409
U.S. Treasury	Treasury Bill	0.209%	10/13/16	196	1,500,000	1,496,891	1,497,720	830
U.S. Treasury	Treasury Bill	0.510%	11/10/16	224	1,500,000	1,492,417	1,497,376	4,960
U.S. Treasury	Treasury Bill	0.757%	12/08/16	252	1,500,000	1,488,777	1,496,427	7,650
U.S. Treasury	Treasury Bill	0.685%	01/05/17	280	1,500,000	1,489,838	1,494,500	4,661
U.S. Treasury	Treasury Bill	0.541%	02/02/17	308	1,500,000	1,491,962	1,493,317	1,355
U.S. Treasury	Treasury Bill	0.673%	03/02/17	336	1,500,000	1,489,990	1,492,364	2,374
U.S. Treasury	Treasury Bill	0.673%	03/30/17	364	1,500,000	1,489,990	1,491,279	1,289
		<u>0.466%</u>		<u>196</u>	<u>\$ 19,500,000</u>	<u>\$ 19,409,988</u>	<u>\$ 19,456,433</u>	<u>\$ 46,447</u>

**Vista Irrigation District
CASH FLOW PROJECTION
March 31, 2016**

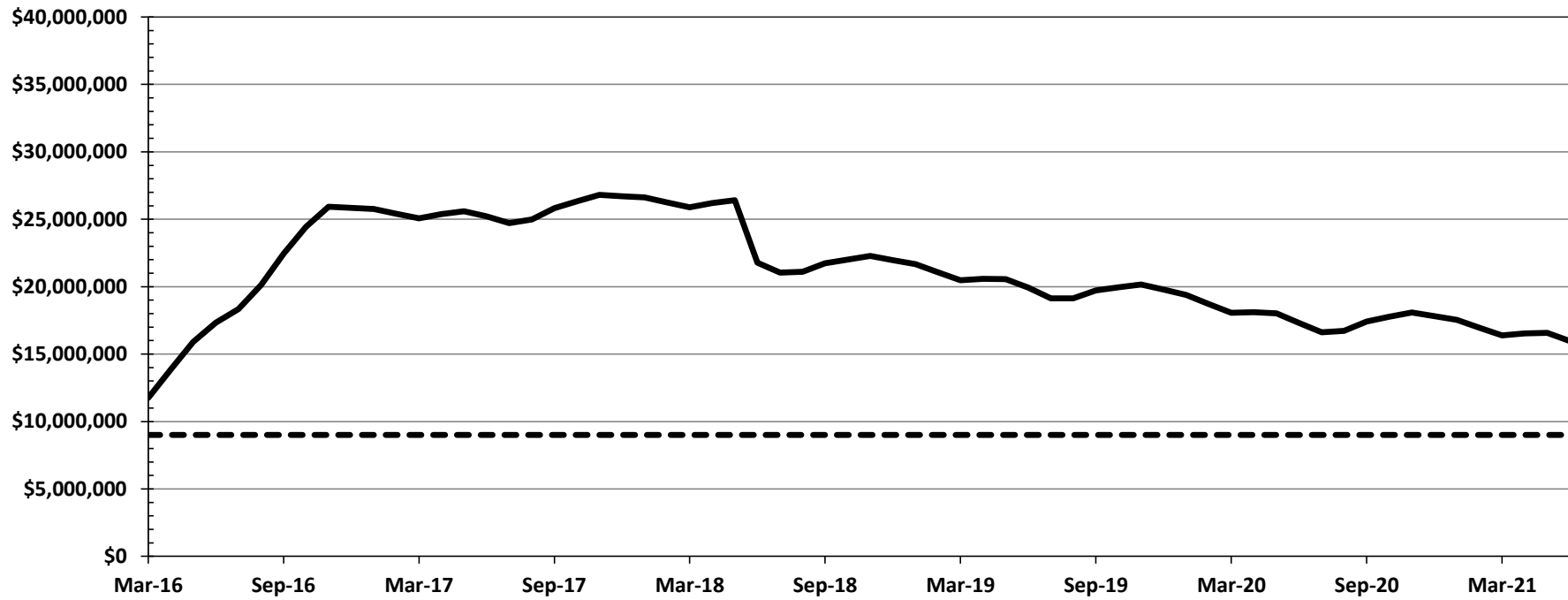

— Projected Cash Balance - - - Working Capital Reserve



STAFF REPORT

Agenda Item: 6.B

Board Meeting Date:	May 11, 2016
Prepared By:	Brian Fisher
Reviewed By:	Marlene Kelleher
Approved By:	Roy Coox

SUBJECT: MICROSOFT SOFTWARE LICENSING AGREEMENT

RECOMMENDATION: Authorize the General Manager to enter into a Microsoft Enterprise Agreement (MEA) with SoftwareOne for the three year period ending May 31, 2019.

PRIOR BOARD ACTION:

04/03/16 Board authorized the General Manager to enter into a MEA with CompuCom for \$34,055 annually for three years ending May 31, 2016, for a total contract price of \$102,165.

FISCAL IMPACT: Annual fees are \$41,860 for the next three years, for a total contract price of \$125,580. The increase is due to changes in IT technology which have resulted in changes to licensing requirements, structures and costs.

SUMMARY: Microsoft regularly provides product upgrades, maintenance releases and patches. With this agreement, the District purchases the right to continued upgrades without interruption, 24 x 7 technical support, unlimited web support, access to the most recent software versions, simplified license tracking and reduced risks of license noncompliance.

DETAILED REPORT: The District has utilized an MEA since 2004. The current agreement expires on May 31, 2016. The agreement offers the District the ability to have a level pay program for software maintenance and upgrades on District computers and servers. This agreement will be for a term of 3 years.

The District took advantage of the group buying power of the County of Riverside in choosing SoftwareOne as the vendor for these licensing services, in accordance with the District's Purchasing Policy in the Rules and Regulations, Section 4.34 (Goals), "*Opportunities for cooperative purchasing, in order to take advantage of similar needs and economies of scale, will be pursued with other public agencies whenever such purchases are feasible and in the best interest of the District.*"

The County of Riverside has been the leader in the negotiations and procurement of the statewide cooperative license purchase agreements for statewide Microsoft Enterprise software and services. There are over 300 governmental agencies in California that utilize this enterprise agreement.

The County of Riverside's volume of licenses for Microsoft products allowed them to obtain deep discounts by going through a competitive bidding process resulting in SoftwareOne being selected as a Microsoft reseller for licensing purposes.

Staff recommends utilizing the group buying power obtained by the County of Riverside by utilizing SoftwareOne's competitively bid rates through this program.

ATTACHMENT: SoftwareOne software quote under the County of Riverside's MEA

SoftwareOne - software quote

Quoted by Aaron Liggitt, SoftwareOne 7171 Forest Lane, Dallas TX 75230

Phone 916-735-3942 aaron.liggitt@compucom.com

Please fax your POs to Client Assistance Center at 800-366-9994. You may call 800-400-9852, option 2, to check status on orders.

Quoted to: **Vista Irrigation District**
Donald Brunt
dbrunt@vid-h2o.org

Date 4/25/16 Pricing to renew EA agreement 6628716 (through 5/31/19).

Important: Please provide the email address of the recipient designated to receive a SoftwareONE "order confirmation"

Quantity	Part #	Description	Unit Price	Ext. Price
Enterprise Products				
128	269-12442	OfficeProPlus ALNG SA MVL Pltfrm	\$ 78.68	\$ 10,071.04
66	AAA-10777	WinEntSAPerUsrFromSA USL ALNG SubsVL MVL Pltfrm PerUsr	\$ 45.73	\$ 3,018.18
39	7F4-00013	VDAPerUsrUSL ALNG SubsVL MVL Pltfrm PerUsr	\$ 70.68	\$ 2,756.52
105	W06-01072	CoreCAL ALNG SA MVL Pltfrm UsrCAL	\$ 38.78	\$ 4,071.90
Additional Products				
105	PGI-00270	ExchgEntCAL ALNG SA MVL UsrCAL wSrvcs	\$ 20.21	\$ 2,122.05
1	395-02504	ExchgSvrEnt ALNG SA MVL	\$ 599.00	\$ 599.00
1	312-02257	ExchgSvrStd ALNG SA MVL	\$ 104.61	\$ 104.61
4	H30-00238	PrjctPro ALNG SA MVL w1PrjctSvrCAL	\$ 160.99	\$ 643.96
1	H04-00268	SharePointSvr ALNG SA MVL	\$ 1,005.38	\$ 1,005.38
10	7NQ-00292	SQLSvrStdCore ALNG SA MVL 2Lic CoreLic	\$ 530.22	\$ 5,302.20
11	D87-01159	VisioPro ALNG SA MVL	\$ 82.63	\$ 908.93
2	MX3-00117	VSEntwMSDN ALNG SA MVL	\$ 969.66	\$ 1,939.32
7	6VC-01254	WinRmtDsktpSrvcsCAL ALNG SA MVL UsrCAL	\$ 19.45	\$ 136.15
2	R39-00396	WinSvrExtConn ALNG SA MVL	\$ 298.57	\$ 597.14
10	P73-05898	WinSvrStd ALNG SA MVL 2Proc	\$ 130.44	\$ 1,304.40
4	P71-07281	WinSvrDataCtr ALNG SASU MVL WinSvrStd 2Proc	\$ 1,819.88	\$ 7,279.52
Product-total				\$ 41,860.30
Sub-Total				\$ 41,860.30
Tax				\$ -
Shipping				No Charge
Total				\$ 41,860.30
			total of 3 years of payments =	\$ 125,580.90

Pass-Through Warranty and Other Rights. As a reseller, end-user warranties and liabilities (with respect to any third party hardware and software products provided by SoftwareONE) shall be provided as a pass-through from the manufacturer of such products. All software products are subject to the license agreement of the applicable software supplier, as provided with the software packaging or in the software at time of shipment.



STAFF REPORT

Board Meeting Date: May 11, 2016
Prepared By: Don Smith
Approved By: Roy Coox

SUBJECT: WELL FIELD MAINTENANCE SERVICES AGREEMENT

RECOMMENDATION: Authorize the General Manager to enter into an agreement with Hidden Valley Pump Systems, Inc. to provide as-needed services on the Warner Ranch to maintain wells and well pumps.

PRIOR BOARD ACTION: None.

FISCAL IMPACT: This contract is for \$100,000 and will be included in the proposed Fiscal Year 2017 Budget.

SUMMARY: Hidden Valley Pump Systems, Inc. (HVPS) has been providing as-needed well field maintenance services to the District on the Warner Ranch for many years. District staff proposes entering into an agreement with HVPS for an as-needed services agreement on a sole source basis for the following reasons.

HVPS has specialized equipment and the expertise for working on commercial wells in a ranch setting. Their proximity to the District's operations enables them to respond to emerging maintenance requirements in a timely and cost effective fashion. HVPS's familiarity with the District's unique operations and working conditions on the Warner Ranch reduces costs by eliminating the time needed to learn the District's system and greatly reducing the need for District staff time to assist HVPS. When competitive bids have been sought for specific wellfield work in the past, HVPS has submitted the most competitive bids. Also, several other north county commercial well contractors have declined to provide estimates for work on the District's "A" series wells as they are uncomfortable with the cleaning of well screens that include a combination of stainless steel wire wrap and louvers.

Due to HVPS's unique qualifications and history of satisfactory performance, the District proposes to move forward with a contract on a sole source basis. In accordance with the District's purchasing policy, the contract will be for one year, with options to renew for two additional one-year periods at the District's discretion, prior to requiring reconsideration and approval of a new contract.

ATTACHMENTS: None.



STAFF REPORT

Agenda Item: 6.D

Board Meeting Date:	May 11, 2016
Prepared By:	Frank Wolinski
Reviewed By:	Don Smith
Approved By:	Roy Coox

SUBJECT: ANNUAL CONTRACT FOR MATERIAL TRANSPORT SERVICES

RECOMMENDATION: Authorize the General Manager to extend the existing contract with Leon Perrault Trucking to provide additional transport services and assorted material for District jobs.

PRIOR BOARD ACTION: On June 17, 2015, the Board authorized the General Manager to enter into a contractual service agreement with Leon Perrault Trucking to transport and provide assorted materials for District jobs for fiscal year 2016.

On March 2, 2016, the Board authorized the General Manager to amend the original contract to increase the not to exceed limit from \$150,000 to \$225,000.

FISCAL IMPACT: This contract is proposed for an amount not to exceed \$225,000.

SUMMARY: During the fiscal year 2016, Leon Perrault Trucking successfully transported materials to and from District jobsites and the District yard. The current contract with Leon Perrault Trucking allows for the District to extend the contract through fiscal year 2017. The cost of service and material (table below) remain the same through fiscal year 2017.

DETAILED REPORT: Historically, utilizing outside materials transport services has led to improved production on the District’s main line replacement program as it has allowed construction crews to focus on main line installations and repair. In May of 2015, the District advertised and solicited bids from material transport companies for the importing of fill material and the exporting of spoils from different jobsites within the District’s service area. As a result of this process, the District entered into a contract with Leon Perrault Trucking for fiscal year 2016, with an option to renew the agreement for two additional one-year periods at the District’s discretion.

Current and proposed transport rates and material costs are:

Company	Material Transport Prices	Material Prices (per ton)			
		Class 2	Class 3	Sand	Rock
Leon Perrault Trucking	\$150.00 per load or \$110 per hour	\$10.00	\$10.00	\$16.00	\$16.00

ATTACHMENTS: None.



STAFF REPORT

Agenda Item: 6.E

Board Meeting Date:	May 11, 2016
Prepared By:	Frank Wolinski
Reviewed By:	Don Smith
Approved By:	Roy Coox

SUBJECT: ANNUAL CONTRACT FOR TRAFFIC CONTROL SERVICES

RECOMMENDATION: Accept bid results and authorize the General Manager to enter into a contractual service agreement with Cecilia’s Safety Services, Inc. to provide traffic control services for District jobs.

PRIOR BOARD ACTION: None.

FISCAL IMPACT: This contract is proposed for an amount not to exceed \$275,000.

SUMMARY: The District advertised and solicited bids from nine contractors to perform traffic control services throughout the District’s service area. In response, the District received two qualified bids. Cecilia’s Safety Services, Inc. responded with the lowest overall bid based on labor rates for flagging and traffic plan services.

DETAILED REPORT: Over the past seven years, the District has increasingly used outside traffic control services in an effort to minimize costs, better utilize District staff and reduce the time that water is out of service during construction and repair. Outsourcing these services provides our customers and field crews a safe and efficient work environment, and also transfers associated risk.

The City of Vista requires the District to supply an approved set of traffic control plans with each project submitted in addition to requiring certified flaggers on all projects. The traffic control service provider will prepare traffic control plans and provide all certified flaggers and insurance per District requirements.

The bids for each man-hour of flagging services (including equipment) were as follows:

Cecilia’s Safety Service, Inc.	\$85/hour (flagging) \$95/hour (overtime) \$95/hour (weekends & holidays)
Statewide Traffic Safety & Signs	\$90/hour (flagging) \$90/hour (overtime) \$130/hour (weekends & holidays)
Co’s Traffic Control, Inc.	Non-responsive
Hudson Safe-T-Lite Rentals	Non-responsive
North County Traffic Control	Non-responsive

ATTACHMENTS: None.



STAFF REPORT

Agenda Item: 6.F

Board Meeting Date: May 11, 2016
Prepared By: Frank Wolinski
Reviewed By: Don Smith
Approved By: Roy Coox

SUBJECT: ANNUAL CONTRACT FOR PATCH PAVING SERVICES

RECOMMENDATION: Authorize the General Manager to extend the existing contract with Joe’s Paving, Inc. to perform patch paving on excavations under 1,500 square feet.

PRIOR BOARD ACTION: On June 17, 2015, the Board approved the bid and authorized the General Manager to enter into a contractual service agreement with Joe’s Paving, Inc. to perform annual patch paving for fiscal year 2016.

FISCAL IMPACT: This contract is proposed for an amount not to exceed \$200,000.

SUMMARY: During fiscal year 2016, Joe’s Paving, Inc. has successfully performed final paving for District excavations under 1,500 square feet. The current contract with Joe’s Paving Inc. allows for the District to extend the contract through fiscal year 2017. The cost of service (table below) remains the same through fiscal year 2017.

DETAILED REPORT: The District generates approximately 15,000 to 20,000 square feet of patch paving throughout the year. In May of 2015, the District advertised and received bids from three qualified paving contractors. Joe’s Paving, Inc. provided the lowest cost per square foot for pavement restoration and the lowest mobilization fee.

Current and proposed patch paving rates:

Base pavement restoration		Cold planing/final cap course	
1-500 sq. ft.	\$4.90 sq. ft.	2-1000 sq. ft.	\$3.65 sq. ft.
501-1000 sq. ft.	\$3.90 sq. ft.	1001-2000 sq. ft.	\$2.50 sq. ft.
1001-1500 sq. ft.	\$3.75 sq. ft.	2001-3000 sq. ft.	\$2.38 sq. ft.
Mobilization Fee			
2-200 sq. ft.	\$250		
201-1500 sq. ft.	\$300		

ATTACHMENTS: None.



STAFF REPORT

Agenda Item: 6.G

Board Meeting Date:	May 11, 2016
Prepared By:	Frank Wolinski
Reviewed By:	Don Smith
Approved By:	Roy Coox

SUBJECT: VALVE OPERATING SYSTEM

RECOMMENDATION: Approve the purchase of an automated valve operating system.

PRIOR BOARD ACTION: The valve operator, controller and hydro-vac system was included in the approved 2016 Budget as Item 16-08 for \$65,000.

FISCAL IMPACT: \$60,082.

SUMMARY: The purchase of a second automated valve operating system will enhance the District's current valve maintenance program, dedicating one system to the valve exercising program.

DETAILED REPORT: On May 18, 2005, the Board approved the purchase of an E.H. Wachs TM-7 valve operator and hydro-vac system that was custom fitted to a newly purchased District vehicle. The Wachs valve operating system has proven to be reliable and has been in use for over a decade. This valve truck has been utilized to perform valve maintenance for city and county overlay projects, emergency and scheduled shutdowns and pot-holing, and has not been exclusively dedicated for the valve exercise program. With the expanded use of traffic control and pot-holing services on District projects, another crew is able to be allocated to exclusively work on the valve exercise program, which is a high priority for the District. The purchase of the second valve operating system will allow for a comprehensive valve exercise program of the approximate 10,000 valves within the District's distribution system. The valve operating system will be mounted by District forces to a new vehicle that was approved in the 2016 Budget that is currently out for bid.

The Wachs controller/data logger uses proprietary software for valve information and tracking that was integrated into the District's Geographic Information System (GIS) when the first valve operating system was purchased. The purchase of a second Wachs automated valve operating system is recommended to alleviate additional GIS integration and to maintain consistency between the two valve operating systems. For support, maintenance and standardization reasons, the Wachs system is recommended as a sole source purchase in accordance with the District's purchasing policy and procedures.

ATTACHMENTS: E.H. Wachs sole source document

April 4, 2016

This letter serves as a sole source document for the Valve Maintenance Trailer (VMT) & Valve Maintenance Skid (VMS) line of products manufactured by E.H. Wachs, Utility Products Division.

The VMT/VMS equipment and accessories are designed, manufactured, assembled and distributed solely by E.H. Wachs. The design of this tool is so unique it is protected under multiple US intellectual property protection laws:

Patent Number [9,188,240](#) – Locking brake system for valve operating machine

Patent Number [9,038,667](#) – Dual arm valve operating machine

Patent Number [8,025,078](#) - Vehicle mountable arm for valve operating machine

Patent Number [5,937,373](#) - Method of controlling an underground fluid flow system

Patent Number [5,381,996](#) - Valve operator

In the domestic US, regional distribution is through direct salesmen or exclusive territory dealers; for your area we currently support sales and service direct from the factory.

To the best of our knowledge, no other vendor manufactures and distributes these or similar items. Please let me know should you need further details.

Sincerely,



Jeff Swiatowy
General Manager
Wachs Utility Products



STAFF REPORT

Agenda Item: 6.H

Board Meeting Date:	May 11, 2016
Prepared By:	Al Ducusin
Reviewed By:	Brian Smith
Approved By:	Roy Coox

SUBJECT: NOTICE OF FEES DOCUMENT AND IMPORTED WATER ENTITLEMENT

RECOMMENDATION: That the Board approve the cancellation of the recorded document titled Notice of Fees Due and Payable Upon Application for Water Service (portion of OD-3R) and approve the Imported Water Entitlement document for a parcel consisting of approximately 1.24 gross acres owned by Lindagreen, L.L.C., located at 2133 North Santa Fe Avenue, Vista, and direct the Secretary to record the documents with the County Recorder (APN 159-240-32; DIV NO 1).

PRIOR BOARD ACTION: None.

FISCAL IMPACT: None.

SUMMARY: On October 4, 1993, the above parcel was annexed into Vista Irrigation District (VID) by Resolution and adopted by the Local Agency Formation Commission (LAFCO) as part of the dissolution of the Bueno Colorado Municipal Water District. The annexation became effective upon certain conditions noted on a recorded document titled Notice of Fees Due and Payable Upon Application for Water Service (OD-3R). The conditions included payment to VID for an in-lieu annexation fee upon application for water service by the landowner.

DETAILED REPORT: On February 10, 2016, the owners paid the in-lieu annexation fee, document fee, and meter fees to receive water service as noted on their recorded document. The approval of the Imported Water Entitlement document will allow the owner to have full water rights for water service.

ATTACHMENTS: See attached map.

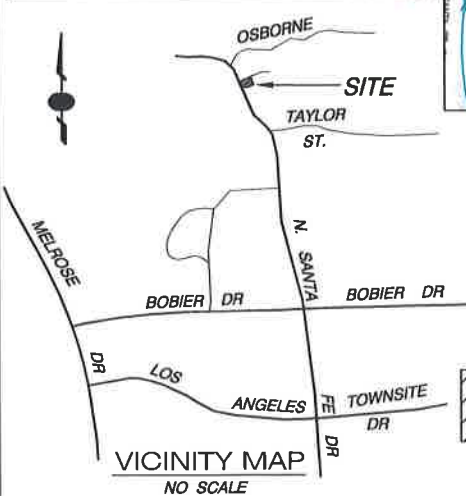
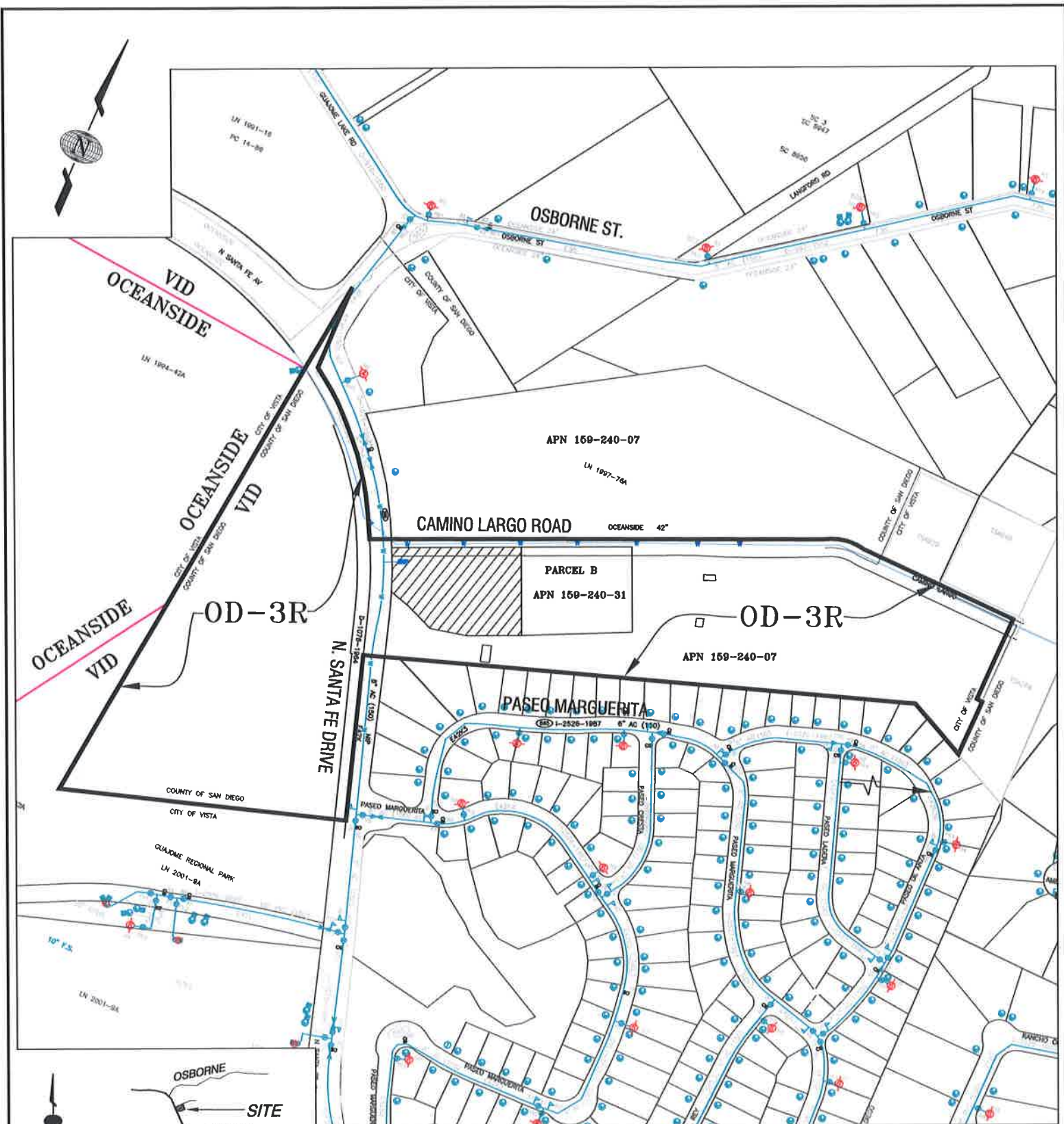

OWNER:
 LINDAGREEN LLC
 4531 QUAILRIDGE DRIVE
 OCEANSIDE, CA 92056-2954
 CONTACT: JOHN MARCONE (760) 717-6708

PORTION OF OD-3R TO CANCEL
 OD-3R NOTICE OF FEES DUE &
 PAYABLE UPON APPLICATION FOR
 WATER SERVICE, DOCUMENT NO.
 1994-0084305.

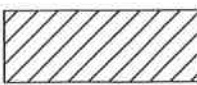

VISTA IRRIGATION DISTRICT			
CANCELLATION OF A PORTION OF OD-3R			
APN	159-240-32	T.B.	1087-G2
SCALE	NOT TO SCALE	L.N.	N/A
APPD. BY	<i>MS</i>	DATE	11/18/15
DRAWN BY	M.S.	DATE	11/18/15
SHEET	1 OF 1	MAP	E8
REVISED			
PATH Z:\Engineering\JOBS\Miscellaneous\WATER RIGHTS\IMPORTED WATER ENTITLEMENT			

Cash Disbursement Report



Payment Dates 4/7/2016 - 4/27/2016

Payment Number	Payment Date	Vendor	Description	Amount
52949	04/13/2016	Apollo Realty Investments, LLC	Customer Refund - Closing	83.34
52950	04/13/2016	Aquajet Art	Pump Cover Flanges (2)	307.80
52951	04/13/2016	ARC Ergonomics	Office Chairs Repairs	152.55
52952	04/13/2016	AT&T Mobility	Air Card	39.01
52953	04/13/2016	Basic pacific	Flexible Benefit Service/Cobra 04/2016	254.00
52954	04/13/2016	CDW Government Inc	Diskeeper Maintenance	4,789.00
	04/13/2016		APC UPS Batteries (3)	940.48
	04/13/2016		Dell 55 Inch Monitor	980.90
52955	04/13/2016	Cecilia's Safety Service Inc	Traffic Control - Cantara Lane	882.00
52957	04/13/2016	Council of Water Utilities	Mtg 04/19/2016 - P Dorey	25.00
	04/13/2016		Mtg 04/19/2016 - R Vasquez	25.00
	04/13/2016		Mtg 04/19/2016 - R Coox	25.00
	04/13/2016		Mtg 04/19/2016 - E Boone	25.00
52958	04/13/2016	Department of Forestry & Fire Protection	Brush/Weed Abatement - Pechstein	456.96
	04/13/2016		Tamarisk Removal Project	2,741.76
52959	04/13/2016	Ergo Works Inc	Ergo Supplies	124.02
52960	04/13/2016	Fastenal	Chain Links - Shop	56.18
52961	04/13/2016	Ferguson Waterworks	Clamp 4x16 Repair Full Circle Stainless Steel	161.81
	04/13/2016		Clamp 10x12 Repair Full Circle Stainless Steel	268.57
	04/13/2016		13x24 C Grey NOHK Lid VID Bee Proof (14)	805.07
	04/13/2016		13x24x12 C Grey HVY Plymr Body (14)	1,108.87
	04/13/2016		End Cap	62.53
52962	04/13/2016	Glennie's Office Products Inc	Office Supplies	120.82
	04/13/2016		Office Supplies	38.37
	04/13/2016		Office Supplies	217.40
52963	04/13/2016	Hanna Plumbing	Flush Kit	119.35
52964	04/13/2016	Hawthorne Machinery Co	Bucket Blade - B20	168.63
	04/13/2016		Filter, Bucket Teeth, Adapters, Retainers	243.73
	04/13/2016		Steering Wheel Knob - L5	44.54
	04/13/2016		Nuts & Bolts - B16	36.29
	04/13/2016		Compaction Wheel Repair	1,380.00
52965	04/13/2016	HD Supply Waterworks	Ell 2" Brass 90 Degree St. (15)	289.30
	04/13/2016		Ell 2" 90 Degree (12)	257.65
	04/13/2016		Ball Valve .75" Lockwing (20)	1,151.40
	04/13/2016		Curb Stop .75" Compression SG (10)	664.23

Payment Number	Payment Date	Vendor	Description	Amount
	04/13/2016		Coupling 4" Deflection C900 (8)	131.07
	04/13/2016		Clamp 1x3 Repair Full Circle 1.32OD Orangeburg (6)	37.76
52966	04/13/2016	Henry Leshar	Reimbursement for Main Line Leak Damage	805.68
52967	04/13/2016	HUB Construction Specialties	Caulk Sealant, Caulk Gun	60.97
52968	04/13/2016	Inland Kenworth (US) Inc	Def Filter, Cabin Air Filter - Truck 3	107.88
52969	04/13/2016	Jo MacKenzie	CSDA Legislative Days 05/17/16-05/18/16	201.96
52970	04/13/2016	Major League Pest/Gemini Pest Control	Pest Control @ VID Headquarter	85.00
52971	04/13/2016	Mike & Wanda Speed	Customer Refund - Overpayment	262.27
52972	04/13/2016	NAPA Auto Parts	Filters, Mud Pump Motor, Spark Plugs	70.56
	04/13/2016		Light/Buzzer - Truck 64	56.76
	04/13/2016		Air & Oil Filters - B16	63.62
52973	04/13/2016	North County Auto Parts	Socket	7.29
	04/13/2016		Torque Wrench	130.15
	04/13/2016		Wipers, Degreaser, Carb Cleaner, Filters	118.58
52974	04/13/2016	North County Lawnmower Inc	Weed Whacker String	53.95
52976	04/13/2016	Pacific Pipeline Supply	Hydrant Construction Meter Parts	294.95
52977	04/13/2016	Parkhouse Tire Inc	(3) Tires & Mounting, Service Call - B16	797.45
52978	04/13/2016	Benetrac	Employee Benefits Tracking 04/2016	400.00
52979	04/13/2016	Pool & Electrical Products Inc	Chlorine	15.82
52980	04/13/2016	R J Safety Supply Co Inc	Rain Gear - Operations	387.84
	04/13/2016		Rain Gear - Operations	331.58
	04/13/2016		Rain Gear - Construction	702.65
	04/13/2016		Rain Gear - Customer Service	314.82
	04/13/2016		Rain Gear - Facilities	314.82
	04/13/2016		Rain Gear - Henshaw	191.12
	04/13/2016		Rain Gear - Safety	224.98
52981	04/13/2016	Ramona Disposal Service	Trash Service 03/2016	153.43
52982	04/13/2016	Robert & Bethany Avila	Customer Refund - Overpayment	149.86
52983	04/13/2016	San Diego Gas & Electric	Electric 03/2016 - Wellfield	17,685.53
	04/13/2016		Electric 03/2016 - T&D	82.71
	04/13/2016		Electric 03/2016 - Reservoirs	38.82
	04/13/2016		Electric 02/2016 - Cathodic Protection & T&D	256.80
	04/13/2016		Electric 02/2016 - Reservoirs	103.02
	04/13/2016		Electric 02/2016 - Pump Stations	8,005.80
	04/13/2016		Electric 02/2016 - Plants	90.28
52984	04/13/2016	Sloan Electric Company	Pump Refurbishment - Station 12/Pump 3	11,154.16
52985	04/13/2016	Southern Counties Lubricants, LLC	Fuel 03/16/16-03/30/16	4,942.03
52986	04/13/2016	Spok, Inc	Pager Service 04/2016	29.07
52987	04/13/2016	State Board of Equalization	March 2016 Use Tax Return	116.00
52988	04/13/2016	Statewide Traffic Safety and Signs, Inc	"Flooded" Signs	301.65

Payment Number	Payment Date	Vendor	Description	Amount
52989	04/13/2016	Tabares Entertainment	Meter Deposit Refund	264.03
52990	04/13/2016	Tegriscap Inc	Landscape Services @ VID and 4 Reservoirs 03/2016	1,675.00
52991	04/13/2016	Tyler Technologies Inc	Utility Billing Software Services	812.50
52992	04/13/2016	UniFirst Corporation	Uniform Service	329.84
52993	04/13/2016	VG Donuts & Bakery Inc	Board Meeting 04/06/2016	31.00
52994	04/13/2016	Vista Firestone Brake & Smog	Tires/Mounting/Alignment (2) - Truck 16	307.21
	04/13/2016		Tire & Mounting - T22	235.56
52995	04/13/2016	Vista Lock & Safe Co	Locks, Key Trigger Snaps	74.71
52996	04/20/2016	ABABA Bolt	Stainless Steel Rods, Nuts, Bolts	29.93
52997	04/20/2016	Accela, Inc #774375	Datastream Maintenance	3,660.00
52998	04/20/2016	ACWA/JPIA	Medical & Dental Insurance 05/2016 - Cobra	138.18
	04/20/2016		Medical & Dental Insurance 05/2016 - Cobra	627.44
	04/20/2016		Medical & Dental Insurance 05/2016 - Employees	144,071.89
	04/20/2016		Medical & Dental Insurance 05/2016 - Retirees	34,640.48
	04/20/2016		Medical & Dental Insurance 05/2016 - M Miller	1,554.56
	04/20/2016		Medical & Dental Insurance 05/2016 - J MacKenzie	1,554.56
	04/20/2016		Medical & Dental Insurance 05/2016 - R Reznicek	2,119.43
	04/20/2016		Medical & Dental Insurance 05/2016 - P Dorey	1,314.08
	04/20/2016		Medical & Dental Insurance 05/2016 - R Vasquez	1,314.08
52999	04/20/2016	ACWA/JPIA	Workers Compensation 01/01/16-03/31/16	72,654.00
53000	04/20/2016	ACWA/JPIA	JPIA Annual Training Conference	160.00
53001	04/20/2016	Airgas USA LLC	Carbon Dioxide	68.88
	04/20/2016		Oxygen & Acetylene	351.52
53002	04/20/2016	Allied Electronics Inc	UPS	295.31
53003	04/20/2016	Ariana Barragan	2016 Water Awareness Poster Contest Winner (3rd)	25.00
53004	04/20/2016	BHA Inc	Henshaw Dam Survey 01/2016	40.00
53005	04/20/2016	Boot World Inc	Footwear Program	175.00
53006	04/20/2016	California Urban Water Conservation Council	2016 Membership Dues	1,845.07
53007	04/20/2016	CDW Government Inc	Recycling fee for Monitors	4.00
	04/20/2016		LVO TS E1922 18.5" LED Monitor	113.93
	04/20/2016		1 Year Annual Client Device Maintenance - Altiris	1,950.00
	04/20/2016		1 Year Annual Server Maintenance Renewal - Altiris	2,400.00
53008	04/20/2016	Cecilia's Safety Service Inc	Traffic Control - Greenbush Lane	1,071.00
	04/20/2016		Traffic Control - Tower Dr	1,071.00
53009	04/20/2016	City of Oceanside	Weese Treatment 03/2016	12,094.43
53010	04/20/2016	Diamond Environmental Services	Portable Restroom Service	85.91
53011	04/20/2016	Digital Deployment, Inc	Website Hosting, Maintenance & Support Service	300.00
53012	04/20/2016	Don Smith	Board Tour 04/12/16 - Staff & Guest (9)	357.12
	04/20/2016		Board Tour 04/12/16 - J MacKenzie	39.68
	04/20/2016		Board Tour 04/12/16 - R Vasquez	39.68

Payment Number	Payment Date	Vendor	Description	Amount
	04/20/2016		Board Tour 04/12/16 - M Miller	39.68
	04/20/2016		Board Tour 04/12/16 - P Dorey	39.68
53013	04/20/2016	Donald Sinclair	Customer Refund - Closing	306.19
53014	04/20/2016	Drug Testing Network Inc	DOT Random Drug Testing	215.00
53015	04/20/2016	FedEx	Express Shipping	64.60
53016	04/20/2016	Ferguson Waterworks	8X6 Flange (2)	379.75
53017	04/20/2016	First Bankcard	Backflow Refresher Workshop	195.00
	04/20/2016		ARC Flash Electrical Safety Workshop	990.00
	04/20/2016		Supervisory Skills Workshop	225.00
	04/20/2016		ACWA 2016 Spring Conference	210.20
	04/20/2016		ACWA 2016 Spring Conference	695.00
	04/20/2016		IPMA-HR Training Conference	165.00
	04/20/2016		IPMA-HR Training Conference	424.00
	04/20/2016		GRA Annual Legislative Symposium - P Dorey	390.51
	04/20/2016		Southern CA Water Committee Mtg - P Dorey	70.00
	04/20/2016		Groundwater Resources Assoc Mtg - P Dorey	30.00
	04/20/2016		CSDA Legislative Days - J MacKenzie	150.00
53018	04/20/2016	Flyers Energy, LLC	Fuel	45.90
53019	04/20/2016	Geib Lumber Company	Nails	4.18
53020	04/20/2016	GLC-(CA) Vista LLC	Solar Energy Use 03/2016	5,943.63
53021	04/20/2016	Glennie's Office Products Inc	Office Supplies	356.95
	04/20/2016		Office Supplies	196.51
53022	04/20/2016	Grainger	Paint, Switch	120.49
	04/20/2016		Caution Decals (6) - T11 & T23	15.09
	04/20/2016		Fuses for BCS Regulator (13)	115.95
53023	04/20/2016	Hawthorne Machinery Co	Stabilizer Pads (2) - B18	254.88
	04/20/2016		Cold Planer Water Block & Fittings - B20	59.12
53024	04/20/2016	HD Supply Waterworks	Coupling 6" Deflection C900 (6)	144.91
	04/20/2016		Air Vent .5" Cast Iron Auto (4)	486.08
53025	04/20/2016	HDR	FERC Relicensing 02/21/156-03/26/16	384.55
53026	04/20/2016	Horton Knox Carter & Foote LLP	Legal 03/2016	34,687.50
53027	04/20/2016	IDEXX Distribution Corporation	Lab Supplies	1,894.85
53028	04/20/2016	InfoSend Inc	Mailing Service 03/2016	5,191.92
	04/20/2016		Data Processing 03/2016	2,073.56
53029	04/20/2016	Iron Mountain Records Management	Offsite Data Storage 03/2016	243.21
53030	04/20/2016	Jackson & Blanc	HVAC Maint at VID Headquarters 04/2016-06/2016	2,178.75
53031	04/20/2016	Jo MacKenzie	ACWA State Legislative Committee Mtg 04/08/16	555.74
53032	04/20/2016	Joe's Paving	Road Repair 03/28/16	8,490.90
	04/20/2016		Road Repair 03/29/16	3,856.80
	04/20/2016		Road Repair 03/31/16	4,309.95

Payment Number	Payment Date	Vendor	Description	Amount
	04/20/2016		Road Repair 04/01/16	1,600.90
53033	04/20/2016	Karen & Gary Van Eik	Customer Refund - Overpayment	334.99
53034	04/20/2016	Ken Grody Ford Carlsbad	Wiring Harnesses for Tail Lamps - T5	93.61
53035	04/20/2016	Lanea Rico	2016 Water Awareness Poster Contest Winner (1st)	100.00
53036	04/20/2016	Leon Perrault Trucking & Materials	Material & Trucking 03/2016	13,435.00
53037	04/20/2016	Lighthouse Inc	Backup Alarm, Tail Lamp	62.58
53038	04/20/2016	Major League Pest/Gemini Pest Control	Bee Removal Services (2)	170.00
53039	04/20/2016	Moody's	Dump Fees (2)	300.00
53040	04/20/2016	NAPA Auto Parts	Relay for AC - Truck 1	15.26
	04/20/2016		Oil Filters, Spray Cleaner	24.12
53041	04/20/2016	North County Auto Parts	Filter, Transmission Fluid - Truck 63	42.15
	04/20/2016		Fuel Filter - Truck 63	11.21
	04/20/2016		Filters - Car 4 & Truck 20	64.43
53042	04/20/2016	Pacific Pipeline Supply	Restrainer Gland	37.92
53043	04/20/2016	Pacific Safety Center	Pesticide Training 03/21/16	995.00
53044	04/20/2016	Packard Government Affairs	San Luis Rey Indian Water Settlement 03/2016	625.00
53045	04/20/2016	R J Safety Supply Co Inc	Rain Gear - Construction	533.87
	04/20/2016		Rain Gear - Customer Service	202.30
	04/20/2016		Rain Gear - Facilities	202.30
	04/20/2016		Rain Gear - Henshaw	134.86
	04/20/2016		Latex Gloves	122.06
53046	04/20/2016	Rancho Environmental Service	Removal of Eucalyptus Trees @ Pechstein	750.00
53047	04/20/2016	RDO Water LLC	Roundup Pro Max	1,441.80
53048	04/20/2016	Rebecca Gutierrez	2016 Water Awareness Poster Contest Winner (2nd)	50.00
53049	04/20/2016	Richard & Richard Construction	Customer Refund - Closing	1,632.15
53050	04/20/2016	Rincon del Diablo MWD	MD Reservoir Water Service 03/2016	30.79
53051	04/20/2016	San Diego Co Superintendent of Schools	Splash Lab Sponsorship 4/4/16 - Temple Heights	725.00
53052	04/20/2016	SoftwareOne Inc	Vmware Maintenance & Support Renewal	17,408.93
53053	04/20/2016	Staples	(3) Gift Cards - Teachers/Poster Contest 2016	120.00
53054	04/20/2016	State Water Resources Control Board	Water System Fees 07-01-15-12/31/15	21,167.55
53055	04/20/2016	TS Industrial Supply	Cutter .5" to 1.25" PVC (4)	218.91
	04/20/2016		First Aid Kit (3)	63.02
	04/20/2016		Cutter 1.5" to 2" PVC	94.75
	04/20/2016		Wrench Three Socket (2)	365.32
	04/20/2016		Wrench 12" Adjustable (4)	125.86
	04/20/2016		Hammer 14" Claw (3)	22.79
	04/20/2016		Wrench 8" Adjustable (4)	69.87
	04/20/2016		Blade Replacement VP-30 PVC (6)	138.66
	04/20/2016		Visqueen Black 20'x100'x.006 (6)	492.16
	04/20/2016		Extension Cord 50' (6)	266.91

Payment Number	Payment Date	Vendor	Description	Amount
	04/20/2016		Extension Cord 25' (6)	169.26
	04/20/2016		Extension Cord 100' (6)	436.17
	04/20/2016		Cutter 150 Copper 1/8" to 1.5" (2)	61.74
53056	04/20/2016	Tyler Technologies Inc	Output Director Maintenance 05/2016 - 04/2017	1,155.00
53057	04/20/2016	Underground Service Alert of Southern California	Dig Alert New Tickets 03/2016	336.00
53058	04/20/2016	UniFirst Corporation	Uniform Service	329.84
53059	04/20/2016	Vista Firestone Brake & Smog	Replaced Ball Joint/Alignment - Truck 63	221.07
53059	04/20/2016	Vista Firestone Brake & Smog	Tires & Mounting (4) - Truck 20	757.59
53060	04/20/2016	Vortex Industries Inc	Preventive Maintenance on Roll-up Doors	553.95
53061	04/20/2016	Vulcan Materials Company and Affiliates	Cold Mix	2,072.09
53062	04/20/2016	Water Education Foundation	Water, More or Less Book	68.75
53063	04/20/2016	WilmerHale	Legal 02/2016	15,010.75
53064	04/27/2016	ARC Ergonomics	Office Chairs (2)	1,082.16
53065	04/27/2016	Audrey Cage	Customer Refund - Closing	743.33
53066	04/27/2016	Big Apple Bagels	All Hands Mtg 03/22/16	58.97
53067	04/27/2016	Blue Shield of CA Life & Health	Vision Insurance 05/2016 - Cobra	14.24
	04/27/2016		Vision Insurance 05/2016 - Employees	1,652.40
	04/27/2016		Vision Insurance 05/2016 - R Vasquez	14.24
	04/27/2016		Vision Insurance 05/2016 - M Miller	14.24
	04/27/2016		Vision Insurance 05/2016 - J MacKenzie	14.24
	04/27/2016		Vision Insurance 05/2016 - R Reznicek	22.54
	04/27/2016		Vision Insurance 05/2016 - P Dorey	14.24
53068	04/27/2016	Brian Fisher	SSL Certificate Renewal	325.00
53069	04/27/2016	Broadway Auto Glass Inc	Rear Window Replacement - Truck 73	198.28
53070	04/27/2016	Canon Solutions America, Inc	Copier Maintenance	39.85
53071	04/27/2016	CDW Government Inc	Chief Single Display Table Stand	179.03
53072	04/27/2016	Cecilia's Safety Service Inc	Traffic Control - Emerald Dr	504.00
53073	04/27/2016	Christopher Craghead	Tuition Reimbursement 04/2016	960.00
53074	04/27/2016	Claudine Smith	Customer Refund - Closing	149.82
53075	04/27/2016	Debbie Pratto	Customer Refund - Closing	23.13
53076	04/27/2016	Direct Energy	Electric 03/2016 - VID	349.60
	04/27/2016		Electric 03/2016 - Henshaw Well Field	13,070.91
	04/27/2016		Electric 03/2016 - T & D / Cathodic Protection	35.06
	04/27/2016		Electric 03/2016 - Reservoirs	13.86
	04/27/2016		Electric 03/2016 - Pump Stations	5,625.08
	04/27/2016		Electric 03/2016 - Treatment Plants	25.60
53077	04/27/2016	Electrical Sales Inc	Seismic Panel	222.55
53078	04/27/2016	Elizabeth A Muehlbauer	Customer Refund - Closing	39.17
53079	04/27/2016	Central Voice	Answering Service	46.00
53080	04/27/2016	Ferguson Waterworks	Gate Valve 10" R/S Cast Iron Flange (2)	3,258.88

Payment Number	Payment Date	Vendor	Description	Amount
	04/27/2016		Wheel Handles for Brass Gate Valves (40)	130.20
53081	04/27/2016	D.H. Maintenance Services	Janitorial Maintenance @ VID 04/2016	1,850.00
53082	04/27/2016	Glennie's Office Products Inc	Office Supplies	416.96
53083	04/27/2016	Grainger	Plug in Relays (2) - Station 9	58.94
	04/27/2016		24 Volt Battery Charger	149.17
53084	04/27/2016	Hach Company	Lab Supplies	677.16
	04/27/2016		Agar Tubes	263.16
53085	04/27/2016	HD Supply Waterworks	Coupling 4" Deflection C900	32.77
	04/27/2016		Gaskets (100)	266.92
53086	04/27/2016	Hydro-Scape Products Inc	Couplings (6)	1.43
53087	04/27/2016	I-15 Express Lanes Customer Service Center	I-15 Express Lane Account - Transponder	200.00
53088	04/27/2016	InfoSend Inc	Support & Storage 03/2016	1,010.39
53089	04/27/2016	James Meredith	Customer Refund - Closing	7.65
53090	04/27/2016	Mabel Daugherty-Eeg	Customer Refund - Closing	963.24
53091	04/27/2016	Major League Pest/Gemini Pest Control	Bee Removal Services (14)	1,190.00
53092	04/27/2016	Matthew Hackett	Customer Refund - Closing	75.26
53093	04/27/2016	Michael Newman	Customer Refund - Closing	100.64
53094	04/27/2016	Moody's	Dump Fees (2)	300.00
53095	04/27/2016	Mutual of Omaha	LTD/STD/ Life Insurance 05/2016	6,268.83
53096	04/27/2016	NAPA Auto Parts	Starter Rope, Electrical Supplies, Hose - Shop	113.91
	04/27/2016		Electronic Wire - Shop	16.81
53097	04/27/2016	North County Auto Parts	Filters, Steering Shock - Truck 48	136.07
	04/27/2016		Filters, Gas Cap, P/S Cap	84.24
	04/27/2016		Tube Sealant, Oil & Air Filter - Truck 72	30.02
	04/27/2016		Air & Oil Filters, Washer Fluid	77.31
53098	04/27/2016	North County Powder Coating Inc	Powder Coating - D2 Regulator SCADA/Solar Post	453.80
53099	04/27/2016	Olivenhain MWD	North San Diego County Regional Recycle Water Project	12,572.29
53100	04/27/2016	Pacific Pipeline Supply	P/O x FlgTee	341.60
53101	04/27/2016	Quality Chevrolet	Coolant Tank & Coolant - Truck 51	273.79
53102	04/27/2016	R J Safety Supply Co Inc	Rain Gear - Warehouse Stock	888.18
	04/27/2016		Rain Gear - Warehouse Stock	668.74
	04/27/2016		Earplugs - Warehouse	252.26
53103	04/27/2016	Ramco Petroleum	Fuel 03/2016	942.57
53104	04/27/2016	RC Auto & Smog	A/C Clutch Coil, Drive Pulley	452.89
53105	04/27/2016	Richard Larsen	D2 Certification Renewal	80.00
53106	04/27/2016	San Diego Gas & Electric	Electric 04/2016 - Ranch House	48.36
53107	04/27/2016	Shred-it USA LLC	Document Destruction	86.11
53108	04/27/2016	Southern Counties Lubricants, LLC	Grease Tubes (30)	131.83
	04/27/2016		Fuel 04/01/16-04/15/16	4,724.08
53109	04/27/2016	WorkPartners Occupational Health Specialists	DMV/DOT Physicals (3)	255.00

Payment Number	Payment Date	Vendor	Description	Amount
53110	04/27/2016	TS Industrial Supply	Spray Wand - Truck 1	57.03
	04/27/2016		Spray Wand - VM1	60.58
	04/27/2016		Washer, Expansion Ring, Hose Repair	21.96
	04/27/2016		Paint, Electrical Tape	178.14
	04/27/2016		Cutter 1.5" to 2" PVC	189.51
53111	04/27/2016	Tyco Integrated Security LLC	Security Monitoring & Maintenance @ VID	2,231.15
53112	04/27/2016	UniFirst Corporation	Uniform Service	329.84
53113	04/27/2016	VG Donuts & Bakery Inc	Board Mtg 04/20/2016	31.00
53114	04/27/2016	Walters Home Management Co	Customer Refund - Closing	39.17
53115	04/27/2016	Warren Environmental, Inc.	Epoxy 6 each 3 gallon kits 301-04 NSF Mastic Grade	2,027.58
53116	04/27/2016	Willock Contracting Inc	Customer Refund - Closing	1,710.67
Grand Total:				592,052.16



STAFF REPORT

Agenda Item: 7

Board Meeting Date: May 11, 2016
Prepared By: Brent Reyes
Reviewed By: Eldon Boone
Approved By: Roy Coox

SUBJECT: PRESENTATION OF AWARDS TO WINNERS OF THE WATER AWARENESS POSTER CONTEST

RECOMMENDATION: Award prizes to the winners of the Water Awareness Poster Contest as follows: 1st place prize of \$100 to Lanea Rico of Mission Meadows Elementary School, 2nd place prize of \$50 to Rebecca Gutierrez of Tri-City Christian School, and 3rd place prize of \$25 to Ariana Barragan of Joli Ann Leichtag Elementary School.

PRIOR BOARD ACTION: This is the twenty-fourth year the District has participated in this event.

FISCAL IMPACT: \$325, including student awards and teacher gift bags.

SUMMARY: A poster contest for fourth graders is sponsored annually by the North County Water Agencies, a group of thirteen northern San Diego county water agencies dedicated to promoting water conservation and awareness. This year's theme was "Be Water Smart." VID received 262 entries. A panel made up of three VID employees selected the winners based on the theme, quality of artwork, originality, and design.

Place	Student	School	Award
1 st	Lanea Rico	Mission Meadows	\$100.00
2 nd	Rebecca Gutierrez	Tri-City Christian	\$ 50.00
3 rd	Ariana Barragan	Joli Ann Leichtag	\$ 25.00

All three posters will appear in the 2017 Water Awareness Calendar published by the North County Water Agencies. VID's first place winner's poster will be featured on the cover or with a month in the calendar, and the second and third place winner's posters will be shown as thumbnails in the calendar. Teachers of the winning students will receive a gift bag in recognition of their efforts.



STAFF REPORT

Agenda Item: 8

Board Meeting Date:	May 11, 2016
Prepared By:	Brett Hodgkiss
Reviewed By:	Eldon Boone
Approved By:	Roy Coox

SUBJECT: SCHOLARSHIP CONTEST AWARD PRESENTATIONS

RECOMMENDATION: Award a \$1,500 scholarship to Nicholas Smith from Tri-City Christian School as the winner of the Vista Irrigation District scholarship contest. Award \$750 scholarships to Marcy Faison from North County Trade Tech High School and Randy Robbins from Rancho Buena Vista High School as runners-up in the scholarship contest.

PRIOR BOARD ACTION: On April 20, 2016, the Board selected the winner and two runners-up for the Vista Irrigation District scholarship contest.

FISCAL IMPACT: \$3,000.

SUMMARY REPORT: In December 2015, application packets for Vista Irrigation District's (VID) scholarship contest were provided to counselors of high schools within the District's jurisdictional boundaries. Follow-up calls were made to the counselors to make sure the application materials were received and inquire as to students' interest in the program. Additional scholarship promotional efforts included: placing information about the scholarship in Rancho Buena Vista High School's monthly scholarship bulletin; recording a segment on the scholarship program for Vista High School's daily video bulletin; issuing a news release; and announcing the program on our on-hold telephone message and web site. Application materials were also made available on the District's web site. The District received six applications by the February 26, 2016 deadline.

Public Affairs Committee members Vásquez and Reznicek were the competition judges. After discussion and careful consideration of the six applications, the Committee made its recommendations regarding the winner and runners-up, which were approved by the Board at their April 20, 2016 meeting. Nicholas Smith from Tri-City Christian School was selected as the winner of the Vista irrigation District scholarship contest and will be awarded a \$1,500 scholarship. Marcy Faison from North County Trade Tech High School and Randy Robbins from Rancho Buena Vista High School were selected as runners-up in the scholarship contest and will each be awarded a \$750 scholarship. Once enrolled at a college, university or trade school, District staff will forward a check to the school on each recipient's behalf.

ATTACHMENTS: Certificates of scholarship award

SCHOLARSHIP VOUCHER

Nicholas Smith

has been awarded a

\$1,500.00 Scholarship

from Vista Irrigation District
in recognition of his academic achievement and
service to the community

A check will be sent directly to the college, university, or trade school of the student's choice upon verification of her acceptance and enrollment as a full-time student.

Richard Vásquez, Board President

Date

SCHOLARSHIP VOUCHER

Marcy Faison

has been awarded a

\$750.00 Scholarship

from Vista Irrigation District
in recognition of her academic achievement and
service to the community

A check will be sent directly to the college, university, or trade school of the student's choice upon verification of her acceptance and enrollment as a full-time student.

Richard Vásquez, Board President

Date

SCHOLARSHIP VOUCHER

Randy Robbins

has been awarded a

\$750.00 Scholarship

from Vista Irrigation District
in recognition of his academic achievement and
service to the community

A check will be sent directly to the college, university, or trade school of the student's choice upon verification of her acceptance and enrollment as a full-time student.

Richard Vásquez, Board President

Date

EXHIBIT A
(1 of 2)

Nicholas P. Smith 2654 Crowthorne Court, Vista, Ca

May 11, 2016

To: The Board of Directors and VID Scholarship Committee

I am very grateful for the opportunity to compete for the 2016 scholarship. As I indicated in my personal statement, I am passionate about the need for reliable and sustainable water.

I am sure as I continue my college career I will have access to classes and people who share some of that same passion since we need to make sure we have resources for our future as well as the next generations.

I am looking forward to attending Cal Poly San Luis Obispo in the Fall, and the scholarship will ease some of the many costs I have yet to incur.

Sincerely,



Nicholas P. Smith

I want to personally
thank the Board of
Directors and
Administrative Staff
for selecting me as an
honorable mention.

This scholarship means
a lot to me, and certainly
will be used toward
my college education.

I am very honored,
and want to once
again thank you all
for your generosity.

EXHIBIT A - Marcy Faison
(2 of 2)



**Water Sustainability
COMMITTEE REPORT**

Agenda Item: 9

Board Meeting Date: May 11, 2016
Prepared By: Dirs. Reznicek & Dorey

SUBJECT: 2016 CALIFORNIA-FRIENDLY LANDSCAPE CONTEST AWARD PRESENTATION

RECOMMENDATIONS: Present a \$250 gift certificate to John and Marcia Rea as the winners of the 2016 Vista Irrigation District California-Friendly Landscape Contest and present a framed certificate to honorable mention recipient Tamara Dias.

PRIOR BOARD ACTION: At its May 13, 2015 meeting, the Board awarded a gift certificate to the winner of Vista Irrigation District's 2015 California-Friendly Landscape Contest and presented a framed certificate to an honorable mention recipient.

FISCAL IMPACT: \$300 for award and plaque.

SUMMARY: The District was asked to take part in the 2016 California-Friendly Landscape Contest jointly coordinated and promoted, but individually judged, by participating agencies. The District accepted the invitation and joined twelve other local agencies (Helix Water District, Olivenhain Municipal Water District, Otay Water District, Padre Dam Municipal Water District, San Dieguito Water District, Santa Fe Irrigation District, Sweetwater Authority, Vallecitos Water District, California American Water, and the cities of Escondido, Oceanside and San Diego) in participating in the landscape contest. The landscape contest winner receives a \$250 gift certificate to a local nursery from the participating agency.

DETAILED REPORT: This is the fourth straight year the District has participated in the landscape contest. Promotional materials were emailed to customers who participated in the Metropolitan Water District of Southern California's turf removal program. Additional landscape contest promotional efforts included: providing flyers to a local nursery, contributing to an ad placed in the Horticultural Society's newsletter, placing promotional materials in the lobby and announcing the contest on the District's website. The District received seventeen applications by the April 8, 2016 deadline.

Water Sustainability Committee members Reznicek & Dorey were the contest judges. The Committee reviewed the applications taking into consideration the following criteria: the overall attractiveness, appropriate plant selection, design, appropriate maintenance, and efficient methods of irrigation. After discussion and careful consideration of the seventeen applications, the Committee selected John and Marcia Rea to be awarded a \$250 gift certificate as the winners of the Vista Irrigation District 2016 California-Friendly Landscape Contest. The Committee also wanted to recognize Tamara Dias's efforts and recognize her as an honorable mention.

The winners were invited to partake in a ceremony, which District staff plans to attend, recognizing all participating agencies' winners at the Water Conservation Garden on May 7, 2016. The winner's landscape will also be featured at www.landscapecontest.com.

ATTACHMENTS: California-Friendly Landscape Contest Applications

California-Friendly Landscape Contest

Sponsored by local water agencies

CONTEST ENTRY DEADLINE: APRIL 8, 2016

Entrant's name

Rich Abrahamowicz

Entrant's daytime phone

Property address: number and street

Entrant's e-mail address

City and zip code

Irrigation system in place and approximate irrigation schedule

Do not irrigate regularly since installed new lanscape. Once per month use water hose to water the landscape.

Approximate date of landscape installation or re-landscaping project

August 2014

By signing the contest application, I authorize publication of photographs I submitted (or those taken by others) of my landscape, and my name and my address for the purpose of promoting water conservation programs.

Check here to have your address withheld from publication of results or promotional materials.

Rich Abrahamowicz

4-3-2016

Signature of account holder

Date signed

Required materials to include with this signed application form:

- 5-10 Photos of your landscape including at least one overall view
- List of the water-wise plants in your landscape
- A copy of your water bill
- A written explanation of why you elected to install a California-friendly landscape, the design and installation process and any unsuspected benefits? **We want to hear your story!**

How did you hear about this landscape contest? (Example: Poster at a local garden and district newsletter)

Water district advertising.

Send your application with other required materials to your servicing water agency listed below:

Note: Only these water agencies are participating in this contest.

California American Water
525 B Street, Suite 300
MS 906 San Diego, CA 92101
Chris Gehrki (619) 533-5312

Helix Water District
7811 University Ave
La Mesa, CA 91942
Ted Salois (619) 667-6257

San Dieguito Water District
160 Calle Magdalena
Encinitas, CA 92024-3721
Felice Tackill (760) 633-2676

City of Escondido
201 North Broadway
Escondido, CA 92025
Kim Silva (760) 839-4076

Olivenhain MWD
1966 Olivenhain Road
Encinitas, CA 92024
Teresa Chase (760) 632-4641

Sweetwater Authority
P.O. Box 2328
Chula Vista, CA 91912
Doug Roberts (619) 409-6881

City of San Diego
525 B Street, Suite 300
MS 906 San Diego, CA 92101
Chris Gehrki (619) 533-5312

Olay Water District
2554 Sweetwater Springs Blvd
Spring Valley, CA 91978
Richard Namba (619) 670-2730

Vallecitos Water District
201 Vallecitos De Oro
San Marcos, CA 92069
Alicia Yerman (760) 744-0460

City of Oceanside
300 North Coast Hwy
Oceanside, CA 92054
Nick Pisano (760) 435-5802

Padre Dam MWD
P.O. Box 719003
Santee, CA 92072
Maggie Buerger
619-258-4613

Vista Irrigation District
1391 Engineer St.
Vista, CA 92081
Brent Reyes (760) 597-3107

*Thank you for sharing
your story, inspiring
others and promoting
water efficient
landscape designs.*

See contest guidelines, judging criteria, landscaping tips and more at www.landscapecontest.com.

Water efficient landscape.

I have installed water efficient landscape mainly for two reasons:

- 1 To save money on my water bill
- 2 To minimize water usage

To water my landscape I use 5 gallon bucket and collect the water from shower as well as the faucets while waiting for hot water for personal use. I estimated about 5 gallons per day is being wasted per adult just waiting for hot water to come out.

During hot summer days once a week or so I do use water hose to make sure plants do not die. It is very minimal. My water bill is around \$100.00 per month which is not that bad considering 3 adults living in my house.

I design the landscape myself and did most of the work. Contractor was hired to remove old lawn. Mixture of colors makes is interesting, hate monotony.

List of plants:

- Caper (Capparis Spinosa)
- Lavender (Lavandula)
- Inch Plant (Tradescantia Pallida)
- Cordylines (Corduline)
- Indiantree Spurge (Euphorbia Tirucalli)
- Yucca (Yucca Glauca)
- Licorice Plant (Helichrysum Petiolare)
- Aeniums (Aenium)
- Pepper Tree

Pre-conversion photo(s) were submitted by customer to the Socalwatersmart turf removal rebate program and have been added to this California Friendly Landscape Contest Application.























CONTEST ENTRY DEADLINE: APRIL 8, 2016

Entrant's name: John DL Arendsen
Entrant's daytime phone: [Redacted]
Property address: number and street: [Redacted]
Entrant's e-mail address: [Redacted]

City and zip code: [Redacted]

Irrigation system in place and approximate irrigation schedule: [Redacted]

Approximate date of landscape installation or re-landscaping project: June 22, 2015

By signing the contest application, I authorize publication of photographs I submitted (or those taken by others) of my landscape, and my name and my address for the purpose of promoting water conservation programs.
 Check here to have your address withheld from publication of results or promotional materials.

Signature of account holder: [Handwritten Signature]
Date signed: April 4, 2016

- Required materials to include with this signed application form:
 5-10 Photos of your landscape including at least one overall view
 List of the water-wise plants in your landscape
 A copy of your water bill
 A written explanation of why you elected to install a California-friendly landscape, the design and installation process and any unsuspected benefits? We want to hear your story!

How did you hear about this landscape contest? (Example: Poster at a local garden and district newsletter)

Email announcement
Send your application with other required materials to your servicing water agency listed below:
Note: Only these water agencies are participating in this contest.

California American Water
525 B Street, Suite 300
MS 906 San Diego, CA 92101
Chris Gehrki (619) 533-5312

City of Escondido
201 North Broadway
Escondido, CA 92025
Kim Silva (760) 839-4076

City of San Diego
525 B Street, Suite 300
MS 906 San Diego, CA 92101
Chris Gehrki (619) 533-5312

City of Oceanside
300 North Coast Hwy
Oceanside, CA 92054
Nick Pisano (760) 435-5802

Helix Water District
7811 University Ave
La Mesa, CA 91942
Ted Salois (619) 667-6257

Olivenhain MWD
1966 Olivenhain Road
Encinitas, CA 92024
Teresa Chase (760) 632-4641

Otay Water District
2554 Sweetwater Springs Blvd
Spring Valley, CA 91978
Richard Namba (619) 670-2730

Padre Dam MWD
P.O. Box 719003
Santee, CA 92072
Maggie Buerger

619-258-4613
San Dieguito Water District
160 Calle Magdalena
Encinitas, CA 92024-3721
Felice Tackill (760) 633-2676

Sweetwater Authority
P.O. Box 2328
Chula Vista, CA 91912
Clay Clifton (619) 409-6779

Vallecitos Water District
201 Vallecitos De Oro
San Marcos, CA 92069
Alicia Yerman (760) 744-0460

Vista Irrigation District
1391 Engineer St.
Vista, CA 92081
Brent Reyes (760) 597-3107

Thank you for sharing your story, inspiring others and promoting water efficient landscape designs.

**WATER SMART LANDSCAPE CONTEST
VISTA IRRIGATION DISTRICT
ATTN: BRENT REYES**

breyes@vid-h20.org

Irrigation system in place and approximate irrigation schedule.

Netafim 1/2" drip @ .9 gal/hr. @ 12" spacing w/added adjustable stream bubblers for large tree.

WATER TIME: 15-20 minutes 3 times per week

LIST OF WATER-WISE PLANTS INSTALLED:

**AGAVE
ATTENUATA
RED AGAVE
BLUE AGAVE
MEXICAN FEATHER GRASS
ECHEVERIA
CALANDRINIA
AZUREUS
AEONIUM
SALVIA LEUCANTHA
CACTUS
LIRIOPE
SEDRUM
GLAUCOPHYLUM
PHORMIUM
CAMELIA
BARREL CACTUS
GREVILLEA
MADAGASCAR PALM
CROWN OF THORNS
DIANELLA
GOLIATH ALOE TREE**

I will be sending you the photos 2 at a time showing before and after photos of front and side yards which were the subject of the **WATER SMART REBATE PROGRAM**

Hi Brent,

I think that's a wrap. However, I would like to give a lot of credit to [Susanna Pagan Landscape Design](#) for her very creative design concept albeit I couldn't follow it to a T as badly as I wanted to due to the overall cost. However, my landscape contractor, Carlos Lopez, owner of [Blue Wave Landscaping](#) in Encinitas did an unbelievable job of facilitating the project within my budgetary parameters.

We have owned this property for 35 years and have raised our 5 children in this home. I personally planted all the trees with the exception of some of the scrub Oak and a few misc indigenous specimens most of which are no longer here.

I couldn't afford to hire a landscape designer and contractor when I purchased this home in 1980 because my wife and I were raising a bunch of kids, paying a mortgage and saving for college educations. So I scrounged around the neighborhood scavenging all the 1 to 5 gallon palms and planted every palm along with all the misc plants and shrubs on my property over the past 3 decades.

I felt really bad because I was starting to see what was once a beautifully manicured and maintained property starting to decline and because of the drought and water restrictions I couldn't water our grass very much and just had to let it start dying out eventually browning our whole landscape.

I was so happy when the Water Smart Rebate Program offered me the incentive and gave me the motivation to re do a good part of my landscape which at the end of the day has turned out to be a very prudent investment not to mention giving me a chance to greatly improve our home overall.

All my neighbors have given us very positive feedback and complements. In fact a few of them even told us that seeing what we did has inspired them to make some drought tolerant improvements on there properties as well. If there's anything else you need please let me know.

Sincerest Regards,

John DL Arendsen

BEFORE: Side yard from east to west



AFTER: Side yard from east to west



BEFORE: Side yard from west to east



AFTER: Side yard from west to east



BEFORE: Front yard from south to north.



AFTER: Front yard from south to north



BEFORE: Front yard from the North looking South



AFTER: Front yard from North to South



Total view of front yard from east to west



Total view of side yard from east to west



Note: I realize that the entry form wanted a photo of the entire project but I couldn't do that because the front and side yard were too far apart to capture it in a single photo and the panoramic option distorted the photo too much.

Here's a photo of the first flowers that bloomed from the cactus within about two months of being planted. This was the cactus in the front yard. I know it exceeds the 10 photo limit but I thought you'd like to see just how quickly some very beautiful results came.





CONTEST ENTRY DEADLINE: APRIL 8, 2016

Entrant's name

PAUL WILLIAM Bloom

Entrant's daytime phone

[Redacted]

Property address: number and street

[Redacted]

Entrant's e-mail address

[Redacted]

City and zip code

[Redacted]

Irrigation system in place and approximate irrigation schedule

AUTOMATIC, MISTER'S, By Hand Sunday, Thursday

* Hand WATER AS needed
* MISTER'S 10 min/day
* 8 min/STA

Approximate date of landscape installation or re-landscaping project

APRIL 17th 2015, Front; Front Flower bed Fall 2015; Side Yd Spring 2016

By signing the contest application, I authorize publication of photographs I submitted (or those taken by others) of my landscape, and my name and my address for the purpose of promoting water conservation programs.

Check here to have your address withheld from publication of results or promotional materials.

Paul Bloom

Signature of account holder

APRIL 8th, 2016

Date signed

Required materials to include with this signed application form:

- 5-10 Photos of your landscape including at least one overall view
- List of the water-wise plants in your landscape
- A copy of your water bill
- A written explanation of why you elected to install a California-friendly landscape, the design and installation process and any unsuspected benefits? **We want to hear your story!**

How did you hear about this landscape contest? (Example: Poster at a local garden and district newsletter)

VID

Send your application with other required materials to your servicing water agency listed below:

Note: Only these water agencies are participating in this contest.

California American Water
525 B Street, Suite 300
MS 906 San Diego, CA 92101
Chris Gehrki (619) 533-5312

Helix Water District
7811 University Ave
La Mesa, CA 91942
Ted Salois (619) 687-6257

San Dieguito Water District
160 Calle Magdalena
Encinitas, CA 92024-3721
Felice Tackhill (760) 633-2676

City of Escondido
201 North Broadway
Escondido, CA 92025
Kim Silva (760) 839-4076

Olivenhain MWD
1966 Olivenhain Road
Encinitas, CA 92024
Teresa Chase (760) 632-4641

Sweetwater Authority
P.O. Box 2328
Chula Vista, CA 91912
Clay Clifton (619) 409-6779

City of San Diego
525 B Street, Suite 300
MS 906 San Diego, CA 92101
Chris Gehrki (619) 533-5312

Otay Water District
2554 Sweetwater Springs Blvd
Spring Valley, CA 91978
Richard Namba (619) 670-2730

Vallecitos Water District
201 Vallecitos De Oro
San Marcos, CA 92069
Alicia Yerman (760) 744-0460

City of Oceanside
300 North Coast Hwy
Oceanside, CA 92054
Nick Pisano (760) 435-5802

Padre Dam MWD
P.O. Box 719003
Santee, CA 92072
Maggie Buerger
619-258-4613

Vista Irrigation District
1391 Engineer St.
Vista, CA 92081
Brent Reyes (760) 597-3107

Thank you for sharing your story, inspiring others and promoting water efficient landscape designs.

To Whom It May Concern,

04/06/2016

California is and will continue to be equated with drought like conditions. Knowing this fact alone should make every homeowner want to conserve as much water as possible. This was and continues to be my primary reason for installing water wise, drought tolerant plants and landscaping.

I found that this process of installing this water saving garden has not only reduced my water use, but also increased the aesthetic look of the entire yard. The use of river rock, the drip system, and mister's in combination with the artificial turf, will provide me with a substantial savings not only now, but in the years to come.

We have also had a patio over installed so as to deflect the heat of the day thereby increasing the life of the patio plants.

Paul W. Bloom

PARTIAL LIST OF PLANTS

1. LEMON LIME JADE
2. Mardi Gras Aeonium
3. Torch cactus
4. Aeonium Zwartkop
5. Beaucarnia Recurvata
6. Bird of Paradise
7. Sago Palm
8. Meditterean Blue Palm
9. Crassula
10. Alpenglow
11. Sedum
12. Australian Tree Fern
13. Graploveria hybrid
14. Flax
15. Grapefruit tree
16. Cactus (varietal)

Pre-conversion photo(s) were submitted by customer to the Socalwatersmart turf removal rebate program and have been added to this California Friendly Landscape Contest Application.













Secured by
ADT
800.369.0996









California-Friendly Landscape Contest

Sponsored by local water agencies

CONTEST ENTRY DEADLINE: APRIL 8, 2016

Entrant's name

Allen & Penny Carlson

Entrant's daytime phone

Property address: number and street

Entrant's e-mail address

City and zip code

Irrigation system in place and approximate irrigation schedule

HAND WATER EVERY TWO WEEKS

Approximate date of landscape installation or re-landscaping project

SPRING 2014

By signing the contest application, I authorize publication of photographs I submitted (or those taken by others) of my landscape, and my name and my address for the purpose of promoting water conservation programs.

Check here to have your address withheld from publication of results or promotional materials.

Allen Carlson

4/7/2016

Signature of account holder

Date signed

Required materials to include with this signed application form:

- 5-10 Photos of your landscape including at least one overall view
- List of the water-wise plants in your landscape
- A copy of your water bill
- A written explanation of why you elected to install a California-friendly landscape, the design and installation process and any unsuspected benefits? **We want to hear your story!**

How did you hear about this landscape contest? (Example: Poster at a local garden and district newsletter)

EMAIL FROM VID

Send your application with other required materials to your servicing water agency listed below:

Note: Only these water agencies are participating in this contest.

California American Water
525 B Street, Suite 300
MS 906 San Diego, CA 92101
Chris Gehrki (619) 533-5312

Helix Water District
7811 University Ave
La Mesa, CA 91942
Ted Salois (619) 667-6257

San Dieguito Water District
160 Calle Magdalena
Encinitas, CA 92024-3721
Felice Tackill (760) 633-2676

City of Escondido
201 North Broadway
Escondido, CA 92025
Kim Silva (760) 839-4076

Olivenhain MWD
1966 Olivenhain Road
Encinitas, CA 92024
Teresa Chase (760) 632-4641

Sweetwater Authority
P.O. Box 2328
Chula Vista, CA 91912
Clay Clifton (619) 409-6779

City of San Diego
525 B Street, Suite 300
MS 906 San Diego, CA 92101
Chris Gehrki (619) 533-5312

Otay Water District
2554 Sweetwater Springs Blvd
Spring Valley, CA 91978
Richard Namba (619) 670-2730

Vallecitos Water District
201 Vallecitos De Oro
San Marcos, CA 92069
Alicia Yerman (760) 744-0460

City of Oceanside
300 North Coast Hwy
Oceanside, CA 92054
Nick Pisano (760) 435-5802

Padre Dam MWD
P.O. Box 719003
Santee, CA 92072
Maggie Buerger
619-258-4613

Vista Irrigation District
1391 Engineer St.
Vista, CA 92081
Brent Reyes (760) 597-3107

Thank you for sharing
your story, inspiring
others and promoting
water efficient
landscape designs.

See contest guidelines, judging criteria, landscaping tips and more at www.landscapecontest.com.

ALLEN & PENNY CARSLON PROJECT

INCENTIVES:

1. Reduce Water Bill

2. Conserve Water

I have been considering re-landscaping our front yard for about two years, due to the cost of watering and to take our responsibility to save water due to the drought California is experiencing. I met with some resistance from my wife and daughter because of their love of a beautiful green lawn. However, they finally came around due to the drought.

So my wife and I began. We took our chairs and moved them around the yard for a couple of weeks at different times of the day to get a sense of what we wanted to see from the many different angles and then developed a master plan. We wanted it to be more than just a drought resistance garden. We began by creating a path to walk around the garden for viewing and easy access to plants. We added a dry creek with a simulated waterfall image. We had a tiered fountain, which developed some cracks, since it no longer could be used as a water fountain, we moved it to a different location and converted into a cactus planter. We wanted to have a sitting area, so we could enjoy the benefits of birds and butterflies, so we built a deck. We added three bird baths to attract a variety of birds. We also have four hummingbird feeders which attract an incredible amount of traffic and the butterflies also have joined the party. We found a rugged bridge to finish off the most perfect image.

My years of enjoying my yard, which means actually doing the all the work (I do all of my own yard work), mowing the lawn, trimming, planting and weeding a half acre lot has given me some knowledge of what was needed to create this new environment. Along with researching a variety of websites, books and driving around to get ideas of what works and what doesn't work is how we proceeded. My wife has a pretty good eye and knows what she wanted to create, which we did by purchasing plants and leaving them in their containers and moving them around until we achieved the look we were happy with (this took many days, many moves and a couple of glasses of wine). We also discovered that we were talking with our neighbors as well as people who were walking their dogs and stopping to chat and we found this to truly be a "California-Friendly Landscape" project).

END RESULT: After all this hard work we are truly enjoying the benefit of our labor. We have our morning coffee and read the newspaper on the deck, while enjoying the spring time flowers and the birds and butterflies. We also enjoy the evenings, and are sometimes joined by neighbors or friends. It has allowed us to reconnect with our neighbors and also enjoy a part of our yard which we did not.

ALLEN & PENNY CARSLON PROJECT



SUMMARY: Total lawn removed: 3450 square feet
Decomposed granite walkway: 80' long by 3' wide
Dry creek: 40' long with a simulated rock waterfall
Additional Items:

- Bridge spanning the dry creek
- 8' by 8' redwood deck, 2 Adirondack chairs and an umbrella
- 3 bird baths
- 4 hummingbird feeders
- 1 water fountain
- At least 50 different rocks and boulders
- 2 half wine barrel containers
- 3 ceramic pots
- 4 trees
- 225+ plants and ground covers
- 7 yards of bark
- Lost a total of 30 pounds between the both of us
- Water billed reduced by 50%

A BIG Thank you to KRC Rock for their invaluable advice and knowledge in creating our dry creek and accents.

We would also like to thank Briggs Nursery and Water Wise Nursery.

ALLEN & PENNY CARSLON PROJECT



PLANT LIST:

COMMON PLANT NAME	BOTANICAL NAME
1. Desert Bird of Paradise	Caesalpnia gilliesii
2. Cowboy Cactus	Euphorbia Ingens
3. Red Star Dracaena Palm	Cordyline Red Star
4. Dwarf Burgandy Flax	Phorimium tenax
5. Caribbean Copper Tree	Euphorbia cotinifolia
6. Bird of Paradise	Strelitzia reginae
7. Hearts of Gold	Cercis Canadensis
8. Bamboo Rush	Chondropetalum tectorum
9. Shrub Daisy	Euryops pectinatus "Viridis"
10. Kaleidoscope abelia	belia grandiflora "Kaleidoscope"
11. Bush mallow	Lavatera maritime
12. Kangaroo paw	Anigozanthos flavidus
13. Sago palm	Cycas revolute
14. desert spoon	Dasyilirion wheeleri
15. Bougainvillea spp	bougainvillea "Torch Glow"
16. Crimson bottlebrush	Callistemo citrinus
17. Sweet pea bush (petite butterfly)	Poligala fruticosa
18. Golden Euonymus	Euonymus japonicus "Ovatus
19. Mexican bush sage	Salvia leucantha
20. Rosaceae - Iceberg/White	Armeria compacta/Rosaceae
21. Rose - Iceberg/Burgandy	Rosaceae
22. Purpureus	Cotinus coggygria
23. Peruvian Lily	Alstroemeria
24. Grass - Mexican Feather	Stipa tenuissima
25. Glauca Pendula (serpentine)	Cedrus atlantica
26. Fountain Grass	Pennisetum setaceum
27. Blue Chip	Buddleja h.
28. Tapien (purple)	Verbena
29. Butterfly Milkweed	Asclepias tuberosa
30. Maiden Grass	Miscanthus Sinensis
31. Lily of the Nile	Agapantha
32. Pigmay Date Palm	Phoenix Roebeleni
33. Dwarf Burgandy New Zealand Flax	Phormiaceae tenax
34. Barrel Cacti	Ferocactus
35. Weeping Blue Cedar	Cedrus deodara atlantica "Glauca pendula"
36. Orchid	Epidendrum orchid



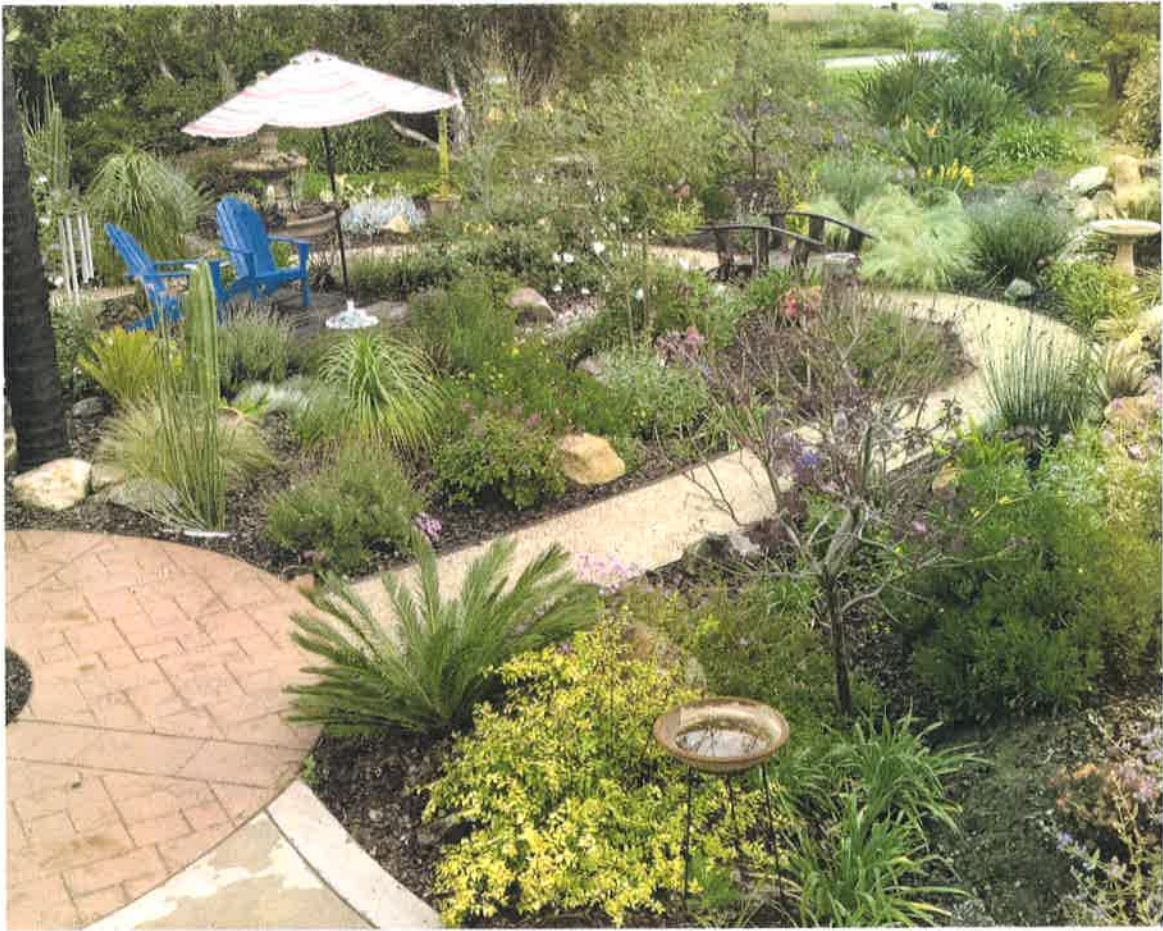





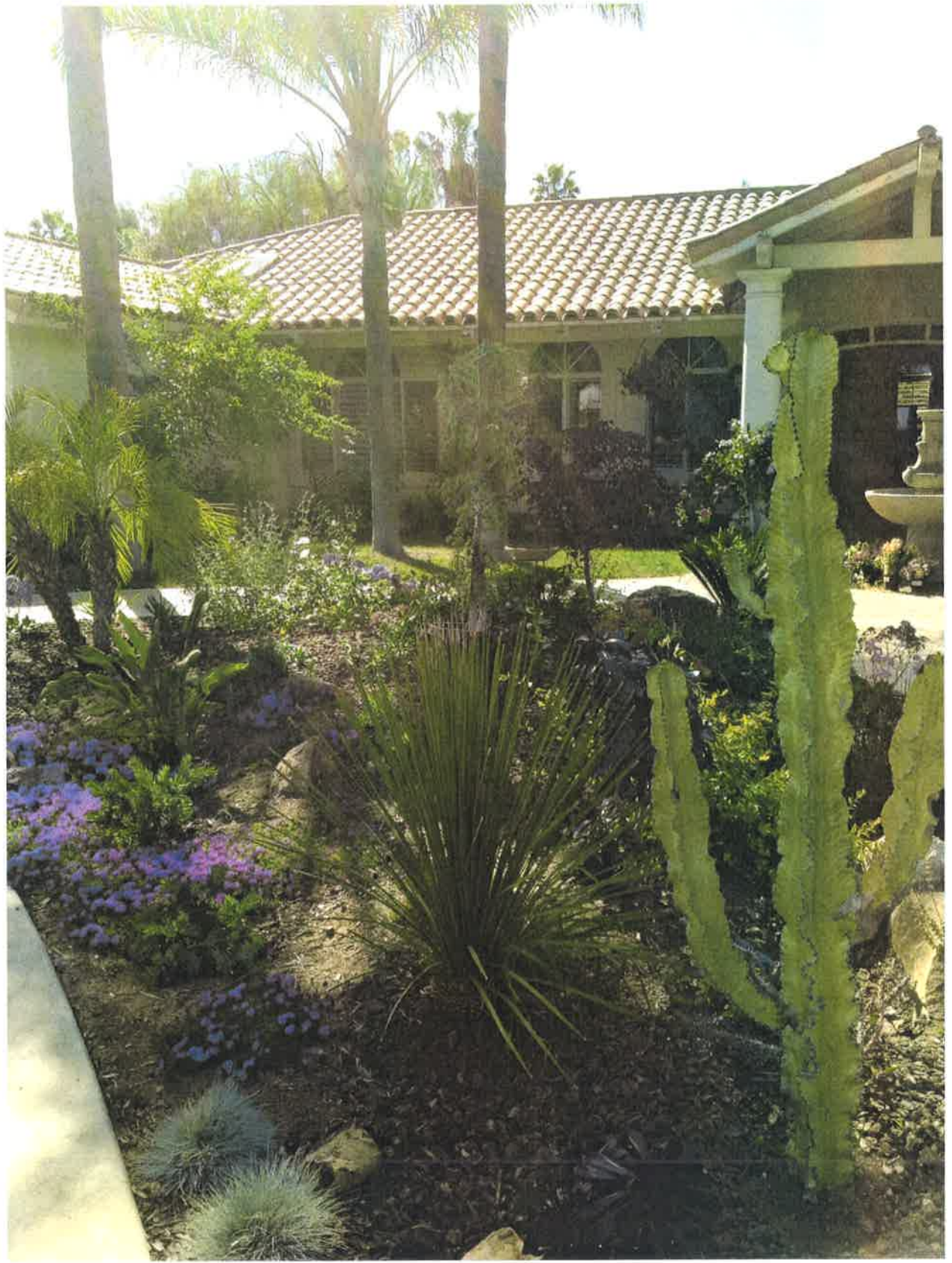





CONTEST ENTRY DEADLINE: APRIL 8, 2016

Entrant's name Tamara Dias Entrant's daytime phone [REDACTED]

Property address: number and street → [REDACTED] Entrant's e-mail address [REDACTED]

City and zip code [REDACTED]

Irrigation system in place and approximate irrigation schedule Drip line with emitters on a timer of 3 times per week at 5 minutes each

Approximate date of landscape installation or re-landscaping project Oct. 2014

By signing the contest application, I authorize publication of photographs I submitted (or those taken by others) of my landscape, and my name and my address for the purpose of promoting water conservation programs.

Check here to have your address withheld from publication of results or promotional materials.

Signature of account holder Tamara Dias Date signed 4-7-16

Required materials to include with this signed application form:

- 5-10 Photos of your landscape including at least one overall view
- List of the water-wise plants in your landscape
- A copy of your water bill
- A written explanation of why you elected to install a California-friendly landscape, the design and installation process and any unsuspected benefits? **We want to hear your story!**

How did you hear about this landscape contest? (Example: Poster at a local garden and district newsletter)

Servicing water agency email.

Send your application with other required materials to your servicing water agency listed below:
 Note: Only these water agencies are participating in this contest.

California American Water
 525 B Street, Suite 300
 MS 906 San Diego, CA 92101
 Chris Gehrki (619) 533-5312

Helix Water District
 7811 University Ave
 La Mesa, CA 91942
 Ted Salois (619) 667-8257

San Dieguito Water District
 160 Calle Magdalena
 Encinitas, CA 92024-3721
 Felice Tackitt (760) 633-2676

City of Escondido
 201 North Broadway
 Escondido, CA 92025
 Kim Silva (760) 839-4076

Olivenhain MWD
 1966 Olivenhain Road
 Encinitas, CA 92024
 Teresa Chase (760) 632-4641

Sweetwater Authority
 P.O. Box 2328
 Chula Vista, CA 91912
 Doug Roberts (619) 409-6881

City of San Diego
 525 B Street, Suite 300
 MS 906 San Diego, CA 92101
 Chris Gehrki (619) 533-5312

Otay Water District
 2554 Sweetwater Springs Blvd
 Spring Valley, CA 91978
 Richard Namba (619) 670-2730

Vallecitos Water District
 201 Vallecitos De Oro
 San Marcos, CA 92069
 Alicia Yerman (760) 744-0460

City of Oceanside
 300 North Coast Hwy
 Oceanside, CA 92054
 Nick Pisano (760) 435-5802

Padre Dam MWD
 P.O. Box 719003
 Santee, CA 92072
 Maggie Buerger
 619-258-4613

Vista Irrigation District
 1391 Engineer St.
 Vista, CA 92081
 Brent Reyes (760) 597-3107

Thank you for sharing your story, inspiring others and promoting water efficient landscape designs.

CA Friendly Landscape Contest 2016

Resident: Tamara Dias [REDACTED] District: VID

List of Water-wise Plants

Lily of the Nile
Agaves
Kangaroo Paws
Aeonium arboreum "Zartkop"
Dymondia
Blue Fescue
Blue Chalk Sticks
New Gold Trailing Lantana
Olive Trees
New Zealand Flax
Blue Oat Grass
CA Wild Red Tea Roses
Mexican feather grass
Rosemary
Bougainvillea
Canary Island Palm
Aloe Vera
Gazania

Why I elected to install a CA friendly landscape.

It was quite simple as I had over 5000 sq. feet of front yard grass. I wanted to save water environmentally and provide a beautiful, colorful front yard that looks beautiful year round regardless of the weather and restriction on water use. In that thought process I had planned on incorporating a tall kinetic art piece as a focal point in the yard to be viewed from within the house and from the street. However, in the weeks and months of plant shopping we found this large Oregon driftwood piece that cried out "art plus water-wise opportunity". Perhaps it could be our focal point in the yard I thought? So we asked the nursery if they could deliver it and make some plant suggestions and with their positive response the driftwood art was our "new baby" for the front yard focal piece.

To give the driftwood more height we turned it on an end side and dressed it up with colorful native succulents. Then we planted towards the top of the driftwood a draping succulent plant to simulate a waterfall. After a few weeks of enjoying our new baby we dressed her up with night lighting by adding 2 solar floodlights. Now she, the driftwood, is a focal point at night for all who drive by including myself as it makes me smile and appreciate nature's beauty both day and night.

Our neighbors were worried when they saw the grass being removed. A few inquires were asking as to whether artificial turf was going in. A couple of neighbors had installed turf in small patches of their front yard. The worry levels were high. But when I told them “no turf” they were indeed relieved but wondered how I was going to replace all that square footage going draught tolerant without being an eye sore.

The installation was a lot of work. It definitely drew attention. Three full weeks to remove everything in the dirt and plant a new dry river bed, irrigation, gravel, plants, trees, walking pavers and then finally mulch. The ultimate “complement” came from individual neighbors who would catch me at the central mailbox and share their amazement on the transformation.

The design took a long time to formulate: the what, how, and where the pieces would come together. We started at The San Diego Botanical Gardens and took photos of plants we liked and ran that by designers at nurseries to see if they would be draught tolerant and low maintenance. We wrote down their recommendations for plants and continually cross checked one’s recommendation to another’s. Like many homeowners, we had bad experiences with landscapers putting in “wrong” plants that would become problems as they matured. We were definitely sensitive to avoiding that.

All in all this yard transformation has been educational and a fun journey. It’s exposed me to a whole new world of plants that are both draught tolerant and uniquely beautiful. I have a new appreciation for large commercial landscapes that are designed with water-wise goals yet a statement of function and beauty. In fact, the “old fashion” grass yards are boring to me now.

While the gophers did enjoy a new crop of roots for a few weeks my dog has adjusted nicely to having mulch instead of grass. The landscape install proved to be an excellent choice in the cool temperature days of November. The plants were able to establish themselves without the summer heat and benefit with the added rain.

Now I happily encourage neighbors that are still suffering with dead grass front yards that there truly is another option. I welcome them to drive by and experience the colorful alternative landscape while living water-wise.

Pre-conversion photo(s) were submitted by customer to the Socalwatersmart turf removal rebate program and have been added to this California Friendly Landscape Contest Application.

















CONTEST ENTRY DEADLINE: APRIL 8, 2016

Entrant's name

Gloria Eck

Entrant's daytime phone

[Redacted]

Property address: number and street

[Redacted]

Entrant's e-mail address

[Redacted]

City and zip code

[Redacted]

Irrigation system in place and approximate irrigation schedule

Left some of the strategic existing Irrigation in place and operate it manually or by timer on designated days if needed.

Approximate date of landscape installation or re-landscaping project

Approval date 6/22. Start date July 18th. We finished a couple of weeks before our deadline of Oct. 20, 2016

By signing the contest application, I authorize publication of photographs I submitted (or those taken by others) of my landscape, and my name and my address for the purpose of promoting water conservation programs.

Check here to have your address withheld from publication of results or promotional materials.

Gloria Eck
Signature of account holder

3/31/2016

Date signed

Required materials to include with this signed application form:

- 5-10 Photos of your landscape including at least one overall view
- List of the water-wise plants in your landscape
- A copy of your water bill
- A written explanation of why you elected to install a California-friendly landscape, the design and installation process and any unsuspected benefits? **We want to hear your story!**

How did you hear about this landscape contest? (Example: Poster at a local garden and district newsletter)

Send your application with other required materials to your servicing water agency listed below:

Note: Only these water agencies are participating in this contest.

California American Water
525 B Street, Suite 300
MS 906 San Diego, CA 92101
Chris Gehrki (619) 533-5312

Helix Water District
7811 University Ave
La Mesa, CA 91942
Ted Salois (619) 667-6257

San Dieguito Water District
160 Calle Magdalena
Encinitas, CA 92024-3721
Felice Tackhill (760) 633-2676

City of Escondido
201 North Broadway
Escondido, CA 92025
Kim Silva (760) 839-4076

Olivenhain MWD
1966 Olivenhain Road
Encinitas, CA 92024
Teresa Chase (760) 632-4641

Sweetwater Authority
P.O. Box 2328
Chula Vista, CA 91912
Doug Roberts (619) 409-6881

City of San Diego
525 B Street, Suite 300
MS 906 San Diego, CA 92101
Chris Gehrki (619) 533-5312

Otay Water District
2554 Sweetwater Springs Blvd
Spring Valley, CA 91978
Richard Namba (619) 670-2730

Vallecitos Water District
201 Vallecitos De Oro
San Marcos, CA 92069
Alicia Yerman (760) 744-0460

City of Oceanside
300 North Coast Hwy
Oceanside, CA 92054
Nick Pisano (760) 435-5802

Padre Dam MWD
P.O. Box 719003
Santee, CA 92072
Maggie Buerger
619-258-4613

Vista Irrigation District
1391 Engineer St.
Vista, CA 92081
Brent Reyes (760) 597-3107

Thank you for sharing your story, inspiring others and promoting water efficient landscape designs.

Our Story:

Our journey to a "drought resistant" garden started in early spring of last year when we could only water 3 days a week. It became difficult to keep our beautiful lawn green, and we were researching drought resistant grass, when we happened upon the rebate information from Vista Irrigation District in our water bill. I went to a seminar on Drought Resistant Landscaping at our local VID which was very helpful. When we applied for the rebate, they were out of funds and we were directed to the Metropolitan Water District. We were approved but then the funds had run out. They were good about letting us know when their funds were in and we had 120 days to complete our project. Our goal was to make our garden a work of art and a peaceful place to enjoy! We hired a landscape designer to sketch the ideas we had and put together a plant list as we were venturing into unknown territory for us. Tropical was all we had known since moving to CA. in 1985. Getting rid of our grass was a project in itself! Our whole family got involved with our project and it was a work of love! Our large tree with its huge canopy was our focal point. We bought an old used cement mixer and got started making our pavers. Having done lots of research on how to make pavers we opted for the method of pouring a puddle of concrete directly on the ground and then shaping it into a paver 2 inches thick. This method makes for a stable walking surface as the pavers don't rock or move. We finished them with a few coats of concrete dye in different colors to get the overall effect we desired. The next step was a round gathering area at the other end of the garden with a path connecting it to the pavers surrounding our large tree. The pathway was lots of fun as the Grandblessings got involved with their artistic skills and ideas! All of the pavers and stepping stones have about a 2 inch depth of smaller stones between them for drainage which has worked very well. We purchased a fountain and filled it with Succulents and "planted" lots of larger rocks that we gathered along the way from people wanting to get rid of them. Smaller rocks were made into miniature retaining walls. Buying our plants and planting them was food for our weary souls after working so many hours in the warmest summer heat on record for many years! Wanting a more lush look of flowering drought resistant plants, we have opted for drought resistant ground cover between our plants rather than bark or rocks. We left a few sprinklers in place that we can turn on when we think our plants are thirsty. The cool winter and the rain have helped with making them almost maintenance free! When our oldest Grandblessing, the welder, came home for Christmas, he welded our large art piece that stands over

Continued: [REDACTED] page 2

our driveway as an entrance to our new and much loved garden! Solar lanterns and solar pathway lights give it a romantic evening glow! We are so happy we took the giant step to undertake this project and love getting our much smaller water bills. The rebate was much appreciated too!

Plant List for [REDACTED]

- 2 Cypress Spiral Topiaries
- 4 Bougainvillea "White Stripe"
- 1 Cordyline fruticosa "Soledad Purple"
- 1 Duranta erecta "Variegata"
- 4 Erigeron Karvinskianus
- 5 Lavandula stoechas "Quasti"
- 2 Leonotis Leonurus
- 10 Myrtus Communis "Variegata"
- 1 Pandorea Jasminoides "Rosea" Stk.
- 2 Salvia Greggii Purple
- 5 Salvia leucantha "Santa Barbara"
- 1 Santolina Chamaecyparissus (grey)
- 1 Flat Scaevola New Wonder
- 1 Flat - Sedum
- 7 Angelonia Species
- 8 Cordyline Purple Towers
- Many numerous succulents and cacti

Pre-conversion photo(s) were submitted by customer to the Socalwatersmart turf removal rebate program and have been added to this California Friendly Landscape Contest Application.

















California-Friendly Landscape Contest

Sponsored by local water agencies

CONTEST ENTRY DEADLINE: APRIL 8, 2016

Entrant's name

Hans & Monika Gaus

Entrant's daytime phone

Property address: number and street

Entrant's e-mail address

City and zip code

Irrigation system in place and approximate irrigation schedule

drip system (1x/week)

Approximate date of landscape installation or re-landscaping project

June/July 2015

By signing the contest application, I authorize publication of photographs I submitted (or those taken by others) of my landscape, and my name and my address for the purpose of promoting water conservation programs.

Check here to have your address withheld from publication of results or promotional materials.

Signature of account holder

Date signed

Required materials to include with this signed application form:

- 5-10 Photos of your landscape including at least one overall view
- List of the water-wise plants in your landscape
- A copy of your water bill
- A written explanation of why you elected to install a California-friendly landscape, the design and installation process and any unsuspected benefits? **We want to hear your story!**

How did you hear about this landscape contest? (Example: Poster at a local garden and district newsletter)

Send your application with other required materials to your servicing water agency listed below:

Note: Only these water agencies are participating in this contest.

California American Water
525 B Street, Suite 300
MS 906 San Diego, CA 92101
Chris Gehrki (619) 533-5312

Helix Water District
7811 University Ave
La Mesa, CA 91942
Ted Salois (619) 667-6257

San Dieguito Water District
160 Calle Magdalena
Encinitas, CA 92024-3721
Felice Tackill (760) 633-2676

City of Escondido
201 North Broadway
Escondido, CA 92025
Kim Silva (760) 839-4076

Olivenhain MWD
1966 Olivenhain Road
Encinitas, CA 92024
Teresa Chase (760) 632-4641

Sweetwater Authority
P.O. Box 2328
Chula Vista, CA 91912
Clay Clifton (619) 409-6779

City of San Diego
525 B Street, Suite 300
MS 906 San Diego, CA 92101
Chris Gehrki (619) 533-5312

Otay Water District
2554 Sweetwater Springs Blvd
Spring Valley, CA 91978
Richard Namba (619) 670-2730

Vallecitos Water District
201 Vallecitos De Oro
San Marcos, CA 92069
Alicia Yerman (760) 744-0460

City of Oceanside
300 North Coast Hwy
Oceanside, CA 92054
Nick Pisano (760) 435-5802

Padre Dam MWD
P.O. Box 719003
Santee, CA 92072
Maggie Buerger
619-258-4613

Vista Irrigation District
1391 Engineer St.
Vista, CA 92081
Brent Reyes (760) 597-3107

*Thank you for sharing
your story, inspiring
others and promoting
water efficient
landscape designs.*

Hans & Monika Gaus

April 6, 2016

Regarding: California-Friendly Landscape Contest

1) Plant list

(this might not be a complete list because we added a few drought-tolerant plants when we went shopping at the nurseries from which we don't have the names anymore):

- Flapjack (*Kalanchoe luciae*)
 - Sticks of fire (*Euphorbia tirucalli*)
 - Black Rose (*Aeonium arboretum*)
 - Paddle plant (*Kalanchoe thyrsiflora*)
 - Baby's necklace (*Crassula rupestris*)
 - Sunset jade (*Crassula ovata*)
 - Coppertone stonecrop (*Sedum nussbaumerianum*)
 - Campfire ((*Crassula capitella*)
 - Echeveria elegans
 - *Sedum rubrotinctum*
 - *Sedum reflexum* (blue spruce)
 - *Sedum Morganium*
 - *Sedum glaucophyllum*
 - Aloe Striata (Coral Aloe)
 - Blue chalk sticks (*Senecio talinoides*)
 - Red yucca (*Hesperaloe parviflora*)
 - *Yucca augustissima*
 - *Aeonium urbicum rubrum*
 - Blue grass (*Festuca glauca*)
 - Crassula finger jade
 - Agave blue glow
- Tree: Fern of the desert (*Lysiloma thornberi*) : we wanted a small, drought-tolerant tree with light shade because we don't have that much space in our front yard and the filtered light of that tree will still allow succulents to grow underneath.

Pre-existing landscape

The fern palm was already planted years ago and we wanted to keep it because it would

give the young plants that needed to establish roots enough shade especially in the afternoon and evening.

- Honey suckle
- Lions tail
- Bird of paradise
- Hawthorne
- Tea tree hedge

2) Water bill

Our latest water bill 12/15/15 – 02/09/16 is similar to the water usage the year before, because we usually turned off our sprinkler system for the lawn in winter during rain season.

The big difference in water usage compared to the previous year shows in the hot summer months (06/15/15 – 08/11/15 change: -41.68 % and 08/11/15- 10/14/15 change: -58.06%)

3) Reason for Installing California-friendly landscape and Water- efficiency

When we immigrated from an European country to California in the mid 1990s we were surprised that so many homeowners had lawns in their front yards although it rained very little in summer.

Over the years we started to love the desert , especially Anza Borrego Desert, and discovered many beautiful plants there. This inspired us to look into succulents and other drought-tolerant plants to enhance our garden.

We installed drip irrigation (as we already have in the majority of our back yard), but have not yet used it. We will do so in summer when we will be on vacation for more than 2 weeks.

Since we changed our front yard from lawn to drought-tolerant landscape (we let the lawn grass die from approximately March –June 2015), we have watered our front yard at least 90-95% with water from our water barrels (1x/week now, and 2-3x/week in the beginning). It rained when we planted the succulents, tree etc.

We have 3 water barrels in the back of our house which are fed from the run-off water from our roof (rain gutters) and added recently another one in the front of the house (behind pillar next to front door).

The mulch keeps the moisture longer around the plants and the decorative rocks in the front area allow the water to be absorbed by the soil. It turned out to be helpful during El Nino rain to have the decorative rocks in the front area as the mulch would have been swept to the street.

The design was made by ourselves, inspired by different ideas we saw at other places.

Sincerely,



Monika Gaus

April 7, 2016

Pre-conversion photo(s) were submitted by customer to the Socalwatersmart turf removal rebate program and have been added to this California Friendly Landscape Contest Application.

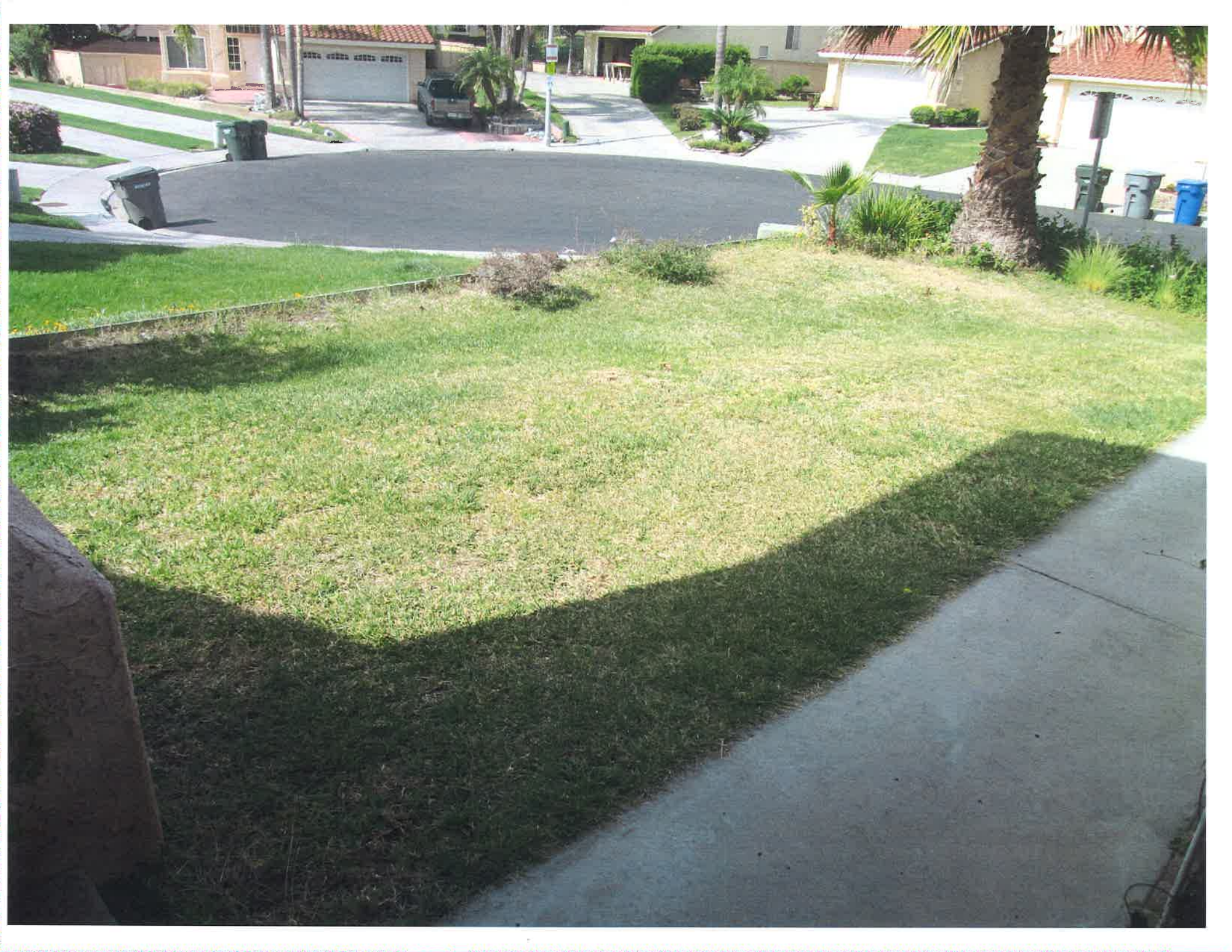











California-Friendly Landscape Contest

Sponsored by local water agencies

CONTEST ENTRY DEADLINE: APRIL 8, 2016

Entrant's name

Gil & Danielle Hooper

Entrant's daytime phone

Property address: number and street

Entrant's e-mail address

City and zip code

Irrigation system in place and approximate irrigation schedule

Drip 2-3 times per week

Approximate date of landscape installation or re-landscaping project

Jan - March 2015

By signing the contest application, I authorize publication of photographs I submitted (or those taken by others) of my landscape, and my name and my address for the purpose of promoting water conservation programs.

Check here to have your address withheld from publication of results or promotional materials.

Melba Hooper

3-8-2016

Signature of account holder

Date signed

Required materials to include with this signed application form:

- 5-10 Photos of your landscape including at least one overall view
- List of the water-wise plants in your landscape
- A copy of your water bill
- A written explanation of why you elected to install a California-friendly landscape, the design and installation process and any unsuspected benefits? **We want to hear your story!**

How did you hear about this landscape contest? (Example: Poster at a local garden and district newsletter)

e-mail from MWD

Send your application with other required materials to your servicing water agency listed below:

Note: Only these water agencies are participating in this contest.

California American Water
525 B Street, Suite 300
MS 906 San Diego, CA 92101
Chris Gehrki (619) 533-5312

Helix Water District
7811 University Ave
La Mesa, CA 91942
Ted Salois (619) 667-6257

San Dieguito Water District
160 Calle Magdalena
Encinitas, CA 92024-3721
Felice Tackill (760) 633-2876

City of Escondido
201 North Broadway
Escondido, CA 92025
Kim Silva (760) 839-4076

Olivenhain MWD
1966 Olivenhain Road
Encinitas, CA 92024
Teresa Chase (760) 632-4641

Sweetwater Authority
P.O. Box 2328
Chula Vista, CA 91912
Clay Clifton (619) 409-6779

City of San Diego
525 B Street, Suite 300
MS 906 San Diego, CA 92101
Chris Gehrki (619) 533-5312

Otay Water District
2554 Sweetwater Springs Blvd
Spring Valley, CA 91978
Richard Namba (619) 670-2730

Vallecitos Water District
201 Vallecitos De Oro
San Marcos, CA 92069
Alicia Yerman (760) 744-0460

City of Oceanside
300 North Coast Hwy
Oceanside, CA 92054
Nick Pisano (760) 435-5802

Padre Dam MWD
P.O. Box 719003
Santee, CA 92072
Maggie Buerger
619-258-4613

Vista Irrigation District
1391 Engineer St.
Vista, CA 92081
Brent Reyes (760) 597-3107

Thank you for sharing
your story, inspiring
others and promoting
water efficient
landscape designs.

The Blooming of Desert Colors In Vista

Our home had about 6,500 square feet of grass. It was planted twenty five years ago by the former owner and required a lot of water and maintenance just to keep it alive. The grass was old and needed a lot of care to bring it back to a reasonable look. While we loved the look and feel of grass, it is just not realistic growing it in the arid climate of Southern California. We began to look at alternatives.

We have always enjoyed the desert scape in all its seasons. The beauty of the flowering succulents, cactuses and the various grasses were always attractive but we never really thought of that for a home scape. After doing some research and looking at various alternatives it quickly became apparent that, if we planned properly, we could choose low water, desert plantings that would rotate their blooms throughout the year and create a different look based upon the seasonal changes.

The project planning was really the hard part. We had some basic hardscape requirements and designed those first. We drew up a plan and decided to remove the rear concrete patio and some walkways and replaced them with water permeable pavers and flagstone. While installing the hardscape, we worked on the soft scape. We had some favorite desert plants and studied what would work in concert with them to produce year around blooms. We went to nurseries and worked with a landscape designer to finalize our choices.

The results are spectacular! The colors are always changing and we are drawn outside every day to enjoy the outdoor living that is available to us in Vista a lot of the year. While we had a good idea what it would look like when it was completed, as the landscape has matured we have been pleasantly surprised by how beautiful a little desert in the city can be.

While there is some maintenance required, it is minimal in comparison to the grass and our watering costs have been significantly reduced. We installed drip irrigation throughout the property. We previously had a very high flow watering system that pumped water out at prodigious rates. Now we water a couple of times a week and we never see the water except for some dampness around the plants afterward.

We are very happy with the changes and would encourage others to consider reducing their water consumption while increasing their enjoyment of their homes with this new 'look and feel' that is the old Southern California that was here before our homes were built.

Gil Hooper

HOOPER RESIDENCE
2086 Oak Leaf Court, Vista, CA 92081

LIST OF WATERWISE PLANTS IN OUR LANDSCAPE

In addition to a couple of established tree and bushes that were already planted from our previous landscape, we added the following:

Aloe Blue Elf

Blue Flame Agave

Desert Spoon

Foxtail Fern

Trailing Lantana

Cordyline Red Star

Fortnight Lily

Russian Sage

AZ Yellow Bells

Kangaroo Paw Yellow

Kangaroo Paw Red

Black Rose Succulent

Desert Bird of Paradise

Evergreen Coral Tree

Crape Myrtle Tree

Bougainvillea

Kniphofia Uvaria

Coprosma "Cappachino" and "Tequila Sunrise"

Aniggozanthos "Harmony" and "Big Red"

Salvia Greggii pink and purple

(PLANTS continued)

Succulents and Cactus X 121

Agave Vilmorinia

Aloe Attenuata

Aloe Arborescens

Erythina Caffra

Cistus Purpureus

Dasyliion Longissima

Ficus Nitidia

Pre-conversion photo(s) were submitted by customer to the Socalwatersmart turf removal rebate program and have been added to this California Friendly Landscape Contest Application.





HOOPER RESIDENCE



HOOPER RESIDENCE



HOOPER RESIDENCE

Back Yard



HOOPER RESIDENCE

Back Yard (continued)





CONTEST ENTRY DEADLINE: APRIL 8, 2016

Entrant's name KAREN FIELDS Entrant's daytime phone
PROPERTY OWNERS JOHN & LORI RNEPP [REDACTED]
 Property address: number and street Entrant's e-mail address
 [REDACTED] [REDACTED]
 City and zip code

Irrigation system in place and approximate irrigation schedule DRIP EVERY 2 WEEKS. NEW PLANTS IRRIGATED
 Approximate date of landscape installation or re-landscaping project ONLY IN PROGRESS SINCE 2008

By signing the contest application, I authorize publication of photographs I submitted (or those taken by others) of my landscape, and my name and my address for the purpose of promoting water conservation programs.
 Check here to have your address withheld from publication of results or promotional materials.

Lori Rnepp 4-1-16
 Signature of account holder Date signed

- Required materials to include with this signed application form:
- 5-10 Photos of your landscape including at least one overall view
 - List of the water-wise plants in your landscape
 - A copy of your water bill
 - A written explanation of why you elected to install a California-friendly landscape, the design and installation process and any unsuspected benefits? **We want to hear your story!**

How did you hear about this landscape contest? (Example: Poster at a local garden and district newsletter)
APPLIED IN 2012 2ND PLACE WINNER - GARDEN IS MUCH BETTER NOW - PLEASE COME FOR A TOUR

Send your application with other required materials to your servicing water agency listed below:
 Note: Only these water agencies are participating in this contest.

California American Water
 525 B Street, Suite 300
 MS 906 San Diego, CA 92101
 Chris Gehrki (619) 533-5312

City of Escondido
 201 North Broadway
 Escondido, CA 92025
 Kim Silva (760) 839-4076

City of San Diego
 525 B Street, Suite 300
 MS 906 San Diego, CA 92101
 Chris Gehrki (619) 533-5312

City of Oceanside
 300 North Coast Hwy
 Oceanside, CA 92054
 Nick Pisano (760) 435-5802

Helix Water District
 7811 University Ave
 La Mesa, CA 91942
 Ted Salois (619) 687-6257

Olivenhain MWD
 1966 Olivenhain Road
 Encinitas, CA 92024
 Teresa Chase (760) 632-4641

Otay Water District
 2554 Sweetwater Springs Blvd
 Spring Valley, CA 91978
 Richard Namba (619) 670-2730

Padre Dam MWD
 P.O. Box 719003
 SanTEE, CA 92072
 Maggie Buerger

619-258-4613
 San Dieguito Water District
 160 Calle Magdalena
 Encinitas, CA 92024-3721
 Felice Tackill (760) 633-2676

Sweetwater Authority
 P.O. Box 2328
 Chula Vista, CA 91912
 Doug Roberts (619) 409-6881

Vallecitos Water District
 201 Vallecitos De Oro
 San Marcos, CA 92069
 Alicia Yerman (760) 744-0460

Vista Irrigation District
 1391 Engineer St.
 Vista, CA 92081
 Brent Reyes (760) 597-3107

Thank you for sharing your story, inspiring others and promoting water efficient landscape designs.

WATERWISE LANDSCAPE AT

HOME OF JOHN AND LORI KNEPP

LANDSCAPE DESIGN AND INSTALLATION
BY
KAREN FIELDS

2016

Over the past 8 years what was once a half acre of weeds is becoming transformed into a waterwise landscape full of native plants, succulents and other drought tolerant plants. Each year more of the yard is being transformed. New plants receive a few minutes of water by drip irrigation every couple of weeks during the summer. Most of the mature plants and trees rely on rain water only. When there is rain, a retention pond catches runoff. Water from the retention pond is used to water new plants. This is my 9th winter staying with my brother, John Knepp. I work on the landscape during the winter adding beds and plants. John and Lori help in the yard and provide maintenance and care during the summers when I have traveled north.

Paths provide the opportunity to wander the property. Native plants and a fountain attract birds, butterflies, lizards, snakes and insects. There are also some small mammals. A resident roadrunner is curious and watches all the changes with interest. Many plants have been chosen for their relationship to a butterfly or bird. Several birdhouses have been placed around the yard hoping to attract blue birds or swallows. The property has been certified as providing wildlife habitat.

A dump truck full of rocks was salvaged from a construction site. The rocks have been used to build walls and create interest in the landscape. A gabion wall was added to create a patio space.

There are two dinosaurs and a dragonfly, original metal sculptures by Ricardo Breceda, the noted Anza-Borrego Desert artist. A herbivore standing over her nest and a carnivore running around a tree are fun for the family and neighbors.

Please come and take a tour of the yard.

This large yard uses very little water. Careful plant selection and appropriate watering techniques have made it very waterwise.

Thank you for your consideration.

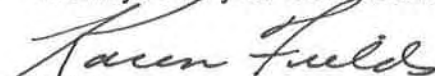
Karen Fields

WATERWISE LANDSCAPE CONTEST 2016

PLANT LIST



By

Karen Fields

Homeowners John and Lori Knepp

I have tried many plant species and varieties. I plant more of the types that survive on low water. I have had success with the following plants.

Sages – many varieties

Ceanothus – many varieties

Manzanita – many varieties

Mallows

Buckwheats – many varieties

Monkey flowers

Penstemon

Toyons

Lemonade Berry

Sugarbush

Laurel Sumac

Oaks

Agaves

Aloes

Lomboy

Silver Senna

California Sunflower

Rushes

Deer Weed

Native Grasses

Plus many others













CONTEST ENTRY DEADLINE: APRIL 8, 2016

Entrant's name

Entrant's daytime phone

Ty Mulken

[Redacted]

Property address: number and street

Entrant's e-mail address

[Redacted]

[Redacted]

City and zip code

[Redacted]

Irrigation system in place and approximate irrigation schedule

Drip Line - water 2 days a week, 10 min.

Approximate date of landscape installation or re-landscaping project

April / May 2015

By signing the contest application, I authorize publication of photographs I submitted (or those taken by others) of my landscape, and my name and my address for the purpose of promoting water conservation programs.

Check here to have your address withheld from publication of results or promotional materials.

[Signature]

3/30/16

Signature of account holder

Date signed

Required materials to include with this signed application form:

- 5-10 Photos of your landscape including at least one overall view
- List of the water-wise plants in your landscape
- A copy of your water bill
- A written explanation of why you elected to install a California-friendly landscape, the design and installation process and any unsuspected benefits? **We want to hear your story!**

How did you hear about this landscape contest? (Example: Poster at a local garden and district newsletter)

e-mail from Vista Irrigation District

Send your application with other required materials to your servicing water agency listed below:

Note: Only these water agencies are participating in this contest.

California American Water
525 B Street, Suite 300
MS 906 San Diego, CA 92101
Chris Gehrki (619) 533-5312

Helix Water District
7811 University Ave
La Mesa, CA 91942
Ted Salois (619) 667-6257

San Dieguito Water District
160 Calle Magdalena
Encinitas, CA 92024-3721
Felice Tackill (760) 633-2676

City of Escondido
201 North Broadway
Escondido, CA 92025
Kim Silva (760) 839-4076

Olivenhain MWD
1966 Olivenhain Road
Encinitas, CA 92024
Teresa Chase (760) 632-4641

Sweetwater Authority
P.O. Box 2328
Chula Vista, CA 91912
Doug Roberts (619) 409-6881

City of San Diego
525 B Street, Suite 300
MS 906 San Diego, CA 92101
Chris Gehrki (619) 533-5312

Otay Water District
2554 Sweetwater Springs Blvd
Spring Valley, CA 91978
Richard Namba (619) 670-2730

Vallecitos Water District
201 Vallecitos De Oro
San Marcos, CA 92069
Alicia Yerman (760) 744-0460

City of Oceanside
300 North Coast Hwy
Oceanside, CA 92054
Nick Pisano (760) 435-5802

Padre Dam MWD
P.O. Box 719003
Santee, CA 92072
Maggie Buerger
619-258-4613

Vista Irrigation District
1391 Engineer St.
Vista, CA 92081
Brent Reyes (760) 597-3107

**Thank you for sharing
your story, inspiring
others and promoting
water efficient
landscape designs.**

breyes@vid-h2o.org

See contest guidelines, judging criteria, landscaping tips and more at www.landscapecontest.com.

Ty Mullen

March 30, 2016

Brent Reyes
Water Conservation Specialist
Vista irrigation District
1391 Engineer Street
Vista, CA 92081

Dear Brent Reyes:

We decided to install a new landscape the beginning of 2015. After researching plants that would do well in southern California I found the SoCal Water smart program. This made all the difference. The benefits of a California friendly landscape were spelled out. We would save money on water costs and lessen our environmental impact over time more than any other type of new landscaping. I contacted a landscaper and decided to go with decomposed granite, plant beds with only drought tolerant plants, and drip lines on a timer.

We've had the new California friendly landscape for almost a year. We've had to do some experimentation with how little water we can get away with using without the plants dying. Also, adjusting for changing seasons was hard to figure out on our own. Thankfully we have only lost a few of our original plants and everything seems to be going well.

I would say the best unexpected benefit of transforming the yard is the reaction and support from people in our neighborhood. We've met so many of our neighbors during the whole process. People have walked by and stopped to chat and ask questions about the yard. We've even had several people drive by honking giving us a thumbs up! Overall it's been a great experience and I'm glad it's turned out so well.

Sincerely,

Ty Mullen

Front Yard

Leucophyllum Texas ranger

Silver germander azureum

Kangaroo paw plant – Red & Orange

Blue Fescue

Aeonium

Penstemon

Tropical Milkweed

Back Yard

Silver germander azureum

Kangaroo paw Red & Orange

Blue Fescue

Aeonium

Salvia greggi red

Penstemon

Bulbine frutescens

Senecio mandraliscae

Tropical Milkweed

Rosemary

Salvia - Sage

Lavender

Pre-conversion photo(s) were submitted by customer to the Socalwatersmart turf removal rebate program and have been added to this California Friendly Landscape Contest Application.







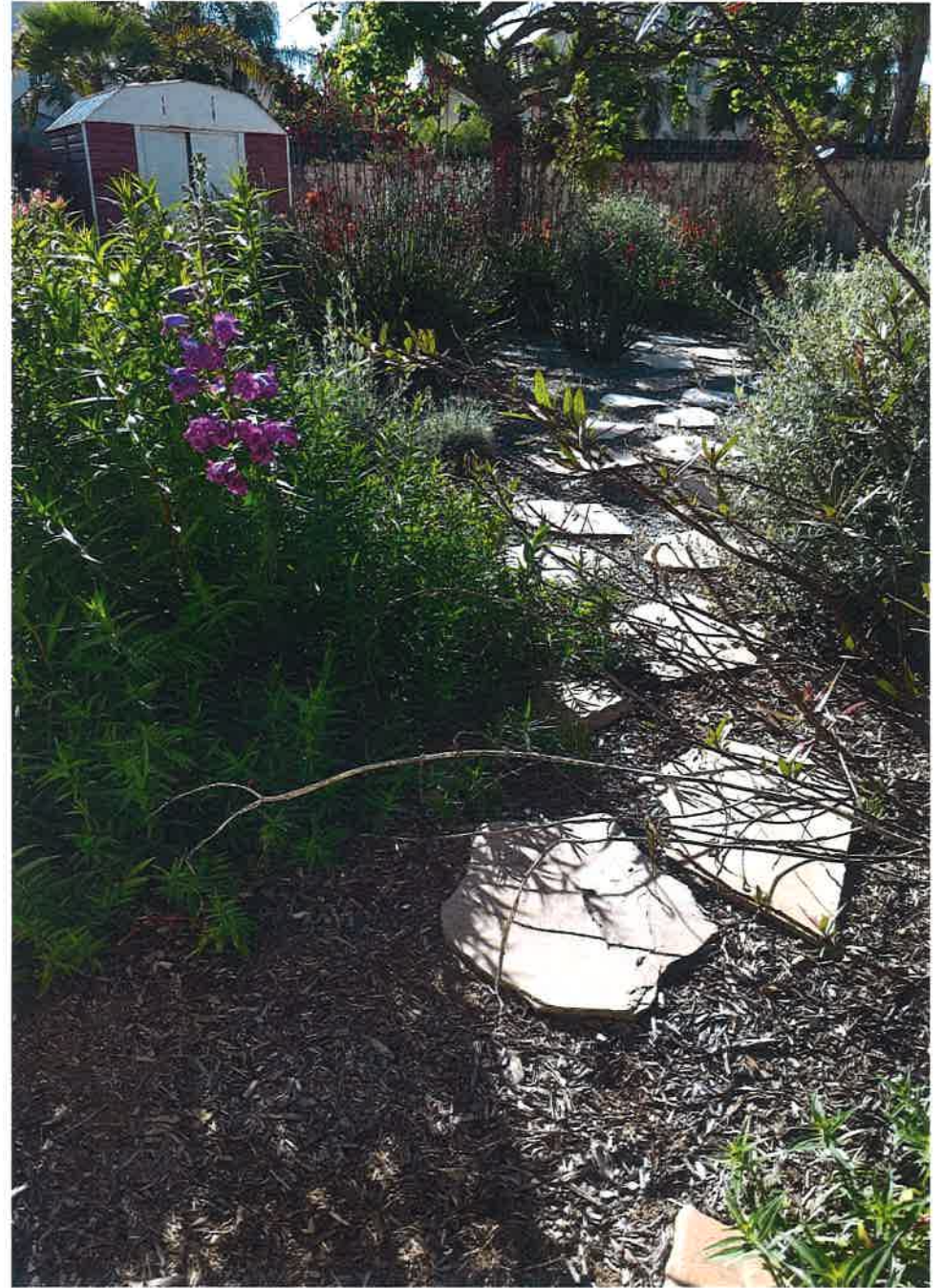

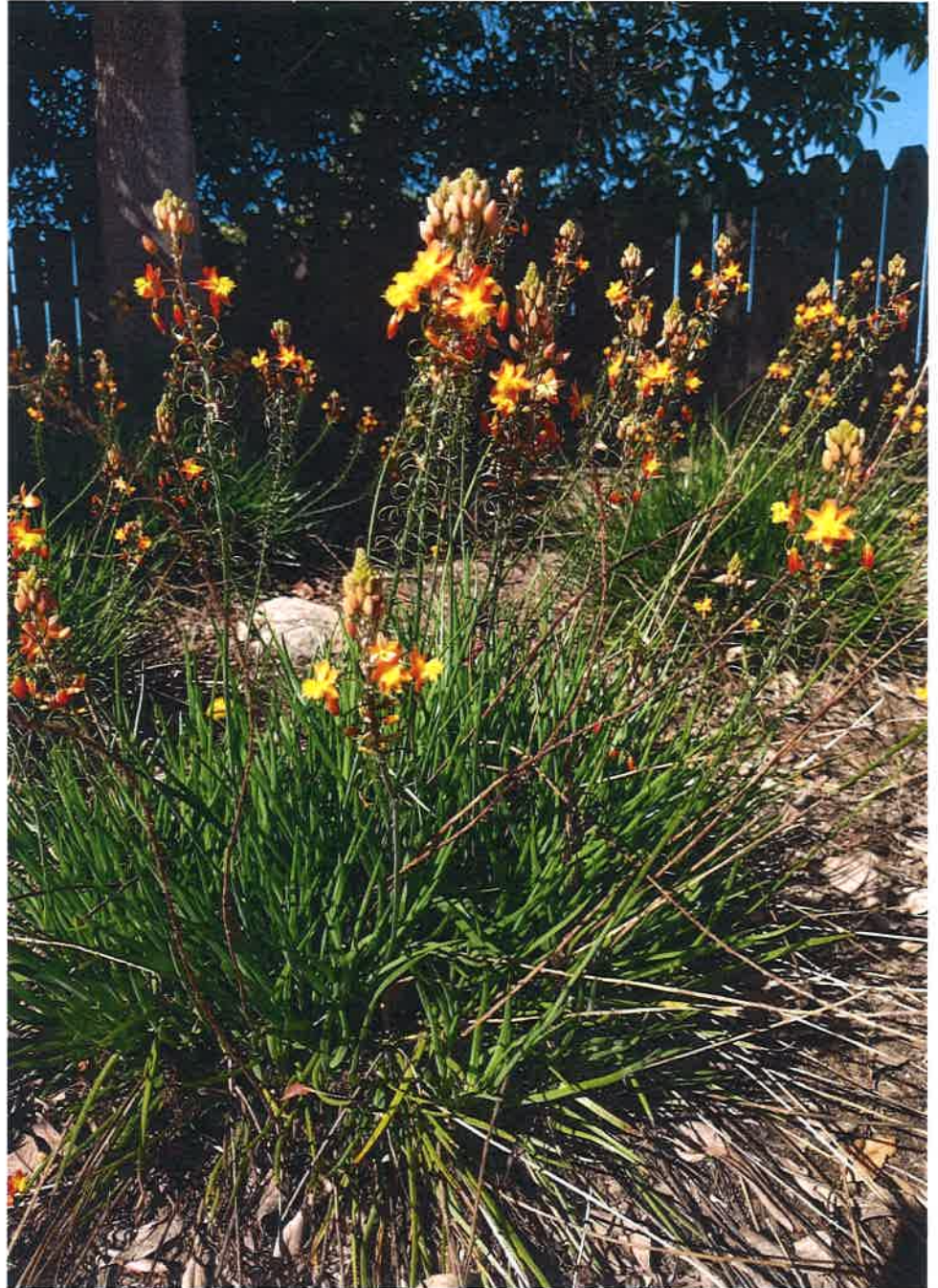





CONTEST ENTRY DEADLINE: APRIL 8, 2016

Entrant's name John & Marcia Rea [Redacted]

Property address: number and street [Redacted] Entrant's e-mail address [Redacted]

City and zip code [Redacted]

Irrigation system in place and approximate irrigation schedule
Yes - 2 days/week @ 3 minutes per session

Approximate date of landscape installation or re-landscaping project
July 2015

By signing the contest application, I authorize publication of photographs I submitted (or those taken by others) of my landscape, and my name and my address for the purpose of promoting water conservation programs.

Check here to have your address withheld from publication of results or promotional materials.

Signature of account holder [Handwritten Signature] Date signed _____

- Required materials to include with this signed application form:
- 5-10 Photos of your landscape including at least one overall view
 - List of the water-wise plants in your landscape
 - A copy of your water bill
 - A written explanation of why you elected to install a California-friendly landscape, the design and installation process and any unsuspected benefits? **We want to hear your story!**

How did you hear about this landscape contest? (Example: Poster at a local garden and district newsletter)
~~Union Tribune Newspaper~~ BRENT REYES (email)

Send your application with other required materials to your servicing water agency listed below.
 Note: Only these water agencies are participating in this contest.

California American Water
 525 B Street, Suite 300
 MS 906 San Diego, CA 92101
 Chris Gehrki (619) 533-5312

Helix Water District
 7811 University Ave
 La Mesa, CA 91942
 Ted Salois (619) 667-6257

San Dieguito Water District
 160 Calle Magdalena
 Encinitas, CA 92024-3721
 Felice Tackill (760) 633-2676

City of Escondido
 201 North Broadway
 Escondido, CA 92025
 Kim Silva (760) 839-4076

Olivenhain MWD
 1966 Olivenhain Road
 Encinitas, CA 92024
 Teresa Chase (760) 632-4641

Sweetwater Authority
 P.O. Box 2328
 Chula Vista, CA 91912
 Doug Roberts (619) 409-6881

City of San Diego
 525 B Street, Suite 300
 MS 906 San Diego, CA 92101
 Chris Gehrki (619) 533-5312

Olay Water District
 2554 Sweetwater Springs Blvd
 Spring Valley, CA 91978
 Richard Namba (619) 670-2730

Vallecitos Water District
 201 Vallecillos De Oro
 San Marcos, CA 92069
 Alicia Yerman (760) 744-0460

City of Oceanside
 300 North Coast Hwy
 Oceanside, CA 92054
 Nick Pisano (760) 435-5802

Padre Dam MWD
 P.O. Box 719003
 Sanjee, CA 92072
 Maggie Buerger
 619-258-4613

Vista Irrigation District
 1391 Engineer St
 Vista, CA 92081
 Brent Reyes (760) 597-3107

Thank you for sharing your story, inspiring others and promoting water efficient landscape designs.

See contest guidelines, judging criteria, landscaping tips and more at www.landscapecontest.com.

Our reasons for converting our turf front yard into a water-wise low maintenance landscape design were three fold. The primary motivation was the desire to have a front yard that would embrace the concept of being water-wise in our current drought environment. Our secondary motivation was that we are looking forward to retirement in the not too distant future and wanted a yard that was low maintenance and worry free to leave when we travel. The third motivating factor was the desire to have an aesthetically pleasing yard in place of dead grass and mostly dead plants. What turned out to be the unexpected bonus, and the very best part of the entire project, was getting to know our neighbors. Our landscaper lives across the street. We chose him because of the fantastic job he did on his own house. We bought the majority of our plants from a second neighbor who is starting his own nursery. During the entire project many of our neighbors would stop as they headed up and down our street to chat about the yard and compliment us on the design. Choosing to "go local" brought us closer to the people and community we live it!

Marcia & John Rea

PLANT LIST FOR THE REA HOUSE 

Various agaves

Various aloes

Various salvias

Lantanas

Various drought tolerant grasses

Coastal Live Oak tree

Mexican Red Bud tree

Various succulents

Kangaroo paw

Pre-conversion photo(s) were submitted by customer to the Socalwatersmart turf removal rebate program and have been added to this California Friendly Landscape Contest Application.





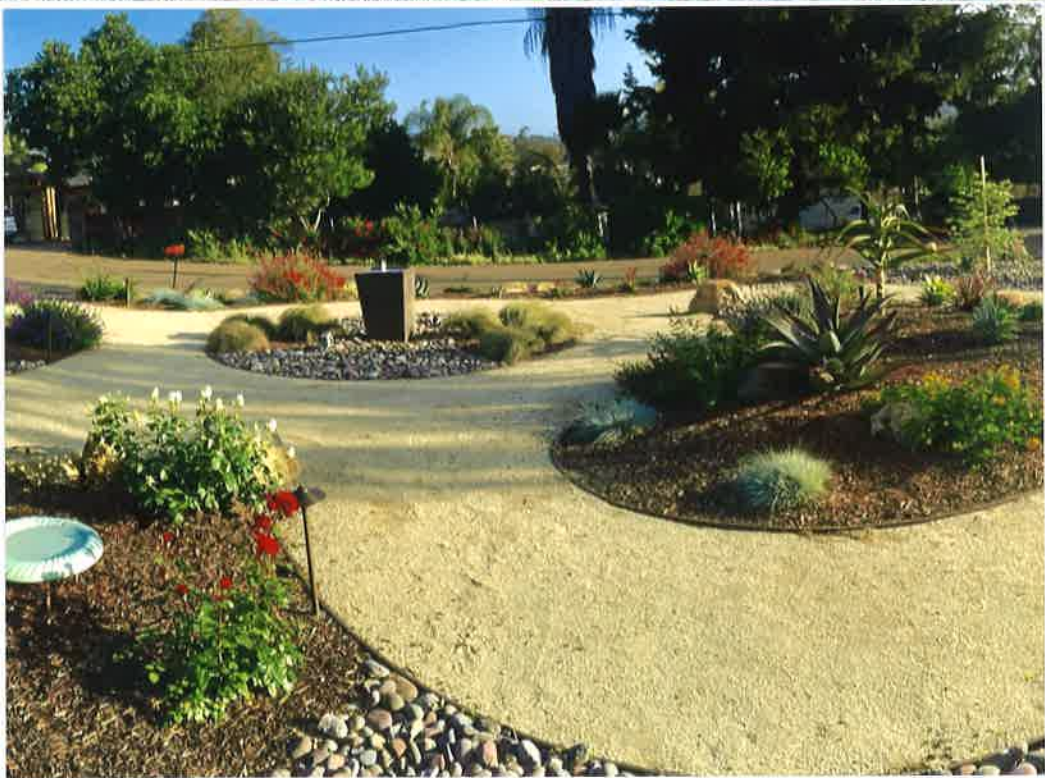



California-Friendly Landscape Contest

Sponsored by local water agencies

CONTEST ENTRY DEADLINE: APRIL 8, 2016

Entrant's name

MARJERI SMITH / HERBIE SMITH

Entrant's daytime phone

Property address: number and street

Entrant's e-mail address

City and zip code

Irrigation system in place and approximate irrigation schedule

HUNTER - DRIP IRRIGATION DAYS: WED / SAT 2 ZONES / 6 MIN EACH

Approximate date of landscape installation or re-landscaping project

MAY 2015 w/ HELP FROM TURF REMOVAL REBATE

By signing the contest application, I authorize publication of photographs I submitted (or those taken by others) of my landscape, and my name and my address for the purpose of promoting water conservation programs.

Check here to have your address withheld from publication of results or promotional materials.

Mary Lind

4 / 8 / 2016

Signature of account holder

Date signed

Required materials to include with this signed application form:

- 5-10 Photos of your landscape including at least one overall view
- List of the water-wise plants in your landscape
- A copy of your water bill
- A written explanation of why you elected to install a California-friendly landscape, the design and installation process and any unsuspected benefits? **We want to hear your story!**

How did you hear about this landscape contest? (Example: Poster at a local garden and district newsletter)

NEWSLETTER / WEBSITE

Send your application with other required materials to your servicing water agency listed below:

Note: Only these water agencies are participating in this contest.

California American Water
525 B Street, Suite 300
MS 906 San Diego, CA 92101
Chris Gehrki (619) 533-5312

Helix Water District
7811 University Ave
La Mesa, CA 91942
Ted Salois (619) 667-6257

San Dieguito Water District
160 Calle Magdalena
Encinitas, CA 92024-3721
Felice Tackhill (760) 633-2676

City of Escondido
201 North Broadway
Escondido, CA 92025
Kim Silva (760) 839-4076

Olivenhain MWD
1966 Olivenhain Road
Encinitas, CA 92024
Teresa Chase (760) 632-4641

Sweetwater Authority
P.O. Box 2328
Chula Vista, CA 91912
Doug Roberts (619) 409-6881

City of San Diego
525 B Street, Suite 300
MS 906 San Diego, CA 92101
Chris Gehrki (619) 533-5312

Otay Water District
2554 Sweetwater Springs Blvd
Spring Valley, CA 91978
Richard Namba (619) 670-2730

Vallecitos Water District
201 Vallecitos De Oro
San Marcos, CA 92069
Alicia Yerman (760) 744-0460

City of Oceanside
300 North Coast Hwy
Oceanside, CA 92054
Nick Pisano (760) 435-5802

Padre Dam MWD
P.O. Box 719003
Santee, CA 92072
Maggie Buerger
619-258-4613

Vista Irrigation District
1391 Engineer St
Vista, CA 92081
Brent Reyes (760) 597-3107

**Thank you for sharing
your story, inspiring
others and promoting
water efficient
landscape designs.**

California-Friendly Landscape Contest Entry

Smith Residence



Property Goals

- Reduce water usage
- Redirect rainfall into the landscape and planting areas
- Increase permeable surfaces
- Implement the usage of bioswales/basins to assist in retaining water onsite
- Establish native plant communities
- Grow food
- Increase usable space
- Create beautiful natural design aesthetic

Water-Wise Plant Palette:

- Aloe
- Blue Fescue
- California Fescue
- Coyote Mint
- Fan Aloe
- Fountain Grass
- Foxtail Agave
- Hummingbird sage
- Kangaroo Paw
- Lavender
- Mexican feather grass
- Mexican Sage
- Myoporum
- Parasol Aeonium
- Pencil Plant
- Pride of Madeira
- Purple Sage
- Rockrose
- Rock Pursulane
- Rose sage
- Rosemary
- Senecio
- Various Echeverria
- Various Jade
- Various Sedum
- Wooly blue curls
- Yucca

Rationale:

Our motivation for installing a California-Friendly landscape was primarily due to our conscious use of precious water resources. When we purchased our first home in May of 2014, we were excited about the prospect of taking on the challenge of converting our front lawn into a beautiful drought-tolerant paradise! In achieving this goal, we wanted to increase the functionality of the yard, attract local wildlife, and integrate a dry creek bed to capture rain run-off, allowing rainwater to stay on-site.

In the process of developing the landscape design, our neighbor became interested in our project and asked if we could create a design concept that incorporated both of our front yards. Although we explored having a landscape design company tackle the project, we decided that it was too cost prohibitive for our budget. I developed a design that included both yards while managing all aspects of the project from removal of the sod, excavation of the creek and swells, selection/installation of plants, installation of drip irrigation, spreading mulch, and lighting installation.

Managing this project was extremely rewarding and has raised many eyebrows in our community. The HOA was thrilled with the outcome despite their initial concerns, given I am not a landscape designer. In less than a year, we have a beautiful water-wise garden that has reduced our water usage by 30%. In addition, we have reduced costs for landscape maintenance (weekly mowing/edging), raised awareness within our community about sustainable landscaping, and become a habitat for abundant wildlife including insects, reptiles, and birds. The functionality of our dry creek bed has performed well during our winter storms, allowing us to capture an abundance of water to recharge the aquifer under our property.

Through out the process we have been engaging our children by conveying the importance of protecting the most important resource on the planet, water. They have become more socially aware and appreciate the results. We have since began projects in our backyard including a grey-water laundry-to-landscape system used to irrigate our fruit trees. We appreciate your consideration for our application and hope our story will inspire others to do their part to conserve.

Peace,
The Smiths















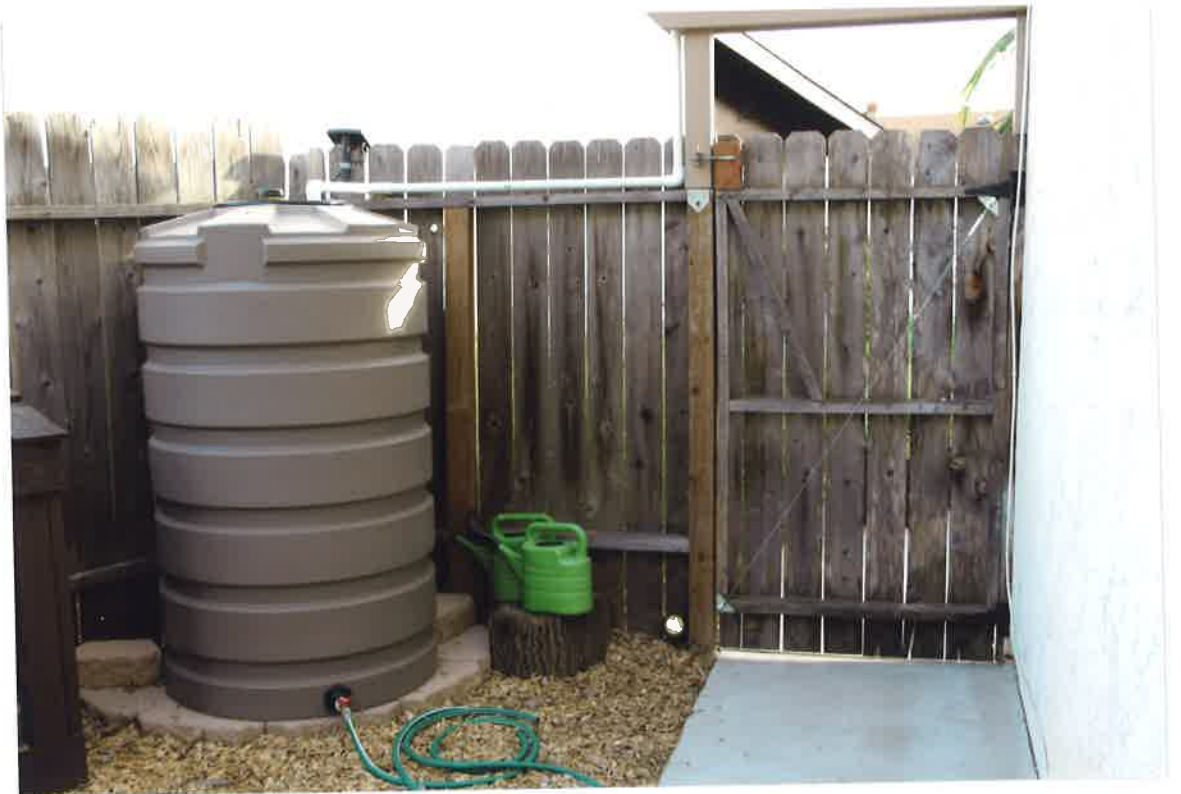

BRENT REYES

VID



CONTEST ENTRY DEADLINE: APRIL 8, 2016

Entrant's name

SHEILA STEARNS

Entrant's daytime phone

[Redacted]

Property address: number and street

[Redacted]

Entrant's e-mail address

[Redacted]

City and zip code

[Redacted]

Irrigation system in place and approximate irrigation schedule

DRIP M, W, F, 5 ZONES 10min EACH

Approximate date of landscape installation or re-landscaping project

Nov 2015

By signing the contest application, I authorize publication of photographs I submitted (or those taken by others) of my landscape, and my name and my address for the purpose of promoting water conservation programs.

Check here to have your address withheld from publication of results or promotional materials.

Sheila Stearns

4-April-16

Signature of account holder

Date signed

Required materials to include with this signed application form:

- 5-10 Photos of your landscape including at least one overall view
- List of the water-wise plants in your landscape
- A copy of your water bill
- A written explanation of why you elected to install a California-friendly landscape, the design and installation process and any unsuspected benefits? **We want to hear your story!**

How did you hear about this landscape contest? (Example: Poster at a local garden and district newsletter)

E-MAILED FROM VID

Send your application with other required materials to your servicing water agency listed below:

Note: Only these water agencies are participating in this contest.

California American Water
525 B Street, Suite 300
MS 906 San Diego, CA 92101
Chris Gehrki (619) 533-5312

Helix Water District
7811 University Ave
La Mesa, CA 91942
Ted Salois (619) 667-6257

San Dieguito Water District
160 Calle Magdalena
Encinitas, CA 92024-3721
Felice Tackill (760) 633-2676

City of Escondido
201 North Broadway
Escondido, CA 92025
Kim Silva (760) 839-4076

Olivenhain MWD
1966 Olivenhain Road
Encinitas, CA 92024
Teresa Chase (760) 632-4641

Sweetwater Authority
P.O. Box 2328
Chula Vista, CA 91912
Doug Roberts (619) 409-6881

City of San Diego
525 B Street, Suite 300
MS 906 San Diego, CA 92101
Chris Gehrki (619) 533-5312

Otay Water District
2554 Sweetwater Springs Blvd
Spring Valley, CA 91978
Richard Namba (619) 670-2730

Vallejitos Water District
201 Vallejitos De Oro
San Marcos, CA 92069
Alicia Yerman (760) 744-0460

City of Oceanside
300 North Coast Hwy
Oceanside, CA 92054
Nick Pisano (760) 435-5802

Padre Dam MWD
P.O. Box 719003
Santee, CA 92072
Maggie Buerger
619-258-4613

Vista Irrigation District
1391 Engineer St.
Vista, CA 92081
Brent Reyes (760) 597-3107

Thank you for sharing
your story, inspiring
others and promoting
water efficient
landscape designs.

California Friendly Landscape Contest



List of plants used on my project

Lantana
Society Garlic
False Heather
New Zealand Tea Bush
Dwarf Bottle Brush
Silva: Red and Purples
Agapanthus
Myoporum Pink
Myoporum Laetum Tree
Purple Fountain Grass
Pink Gaura
Colandreas
Blue Potato Bush
Coleus

My Story

My front lawn hadn't been looking too well the last few years. I had always been mindful of how long the sprinklers ran but it just got harder and harder to keep the grass lush and green with out pouring more and more money on water, chemicals and fertilizers.

The thought of taking out my once beautiful lawn always bothered me because I could never imagine anything that was as nice looking. Visions of drab rocks and prickly cactus held no appeal; however with concerns over our water supply and the increasing difficulty of maintaining a yard so large, made

me reconsider. I went to parks that showcased California friendly landscaping to learn more about what I could do.

I decided that I had a great area that could become a beautiful retreat that was comfortable and welcoming without all the lawn. I chose to create curved and terraced retaining walls using tan stackable blocks. We installed a complete new drip system to water new plants that appealed to Humming Birds and look bright and cheery then we covered weed screen with wood chips. We put in golden rocks throughout the common area, a short winding, compacted DG pathway with stepping stones. Then I designed a travertine patio seating area with a small propane fire ring as the focal point and installed LED accent lighting all around to make the revamped area welcoming day or night.

Although I did all this, and I'm just a novice, I am so pleased with how well my front yard turned out. That's why I am entering this contest. I wanted to encourage others to see first hand how nice and enjoyable a yard can be without traditional turf. I'm not done yet... there are still some wonderful things I plan on incorporating into my water-wise front yard. Be creative and with an open mind take the leap and go California Friendly Landscaping!





















California-Friendly Landscape Contest

Sponsored by local water agencies

CONTEST ENTRY DEADLINE: APRIL 8, 2016

Entrant's name

Melissa Symington

Entrant's daytime phone

[REDACTED]

Property address: number and street

[REDACTED]

Entrant's e-mail address

City and zip code

[REDACTED]

Irrigation system in place and approximate irrigation schedule

Rainbird Smart controller with drip / No schedule - OFF to area

Approximate date of landscape installation or re-landscaping project

August 2014 - November 2014

By signing the contest application, I authorize publication of photographs I submitted (or those taken by others) of my landscape, and my name and my address for the purpose of promoting water conservation programs.

Check here to have your address withheld from publication of results or promotional materials.

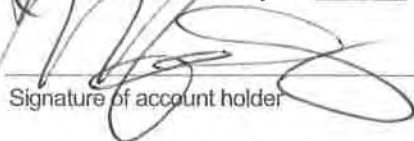

Signature of account holder

3/27/16
Date signed

Required materials to include with this signed application form:

- 5-10 Photos of your landscape including at least one overall view - via email
- List of the water-wise plants in your landscape
- A copy of your water bill
- A written explanation of why you elected to install a California-friendly landscape, the design and installation process and any unsuspected benefits? **We want to hear your story!**

How did you hear about this landscape contest? (Example: Poster at a local garden and district newsletter)

District newsletter; newspaper article

Send your application with other required materials to your servicing water agency listed below:

Note: Only these water agencies are participating in this contest.

California American Water
525 B Street, Suite 300
MS 906 San Diego, CA 92101
Chris Gehrki (619) 533-5312

Helix Water District
7811 University Ave
La Mesa, CA 91942
Ted Salois (619) 667-6257

San Dieguito Water District
160 Calle Magdalena
Encinitas, CA 92024-3721
Felice Tackill (760) 633-2676

City of Escondido
201 North Broadway
Escondido, CA 92025
Kim Silva (760) 839-4076

Olivenhain MWD
1966 Olivenhain Road
Encinitas, CA 92024
Teresa Chase (760) 632-4641

Sweetwater Authority
P.O. Box 2328
Chula Vista, CA 91912
Doug Roberts (619) 409-6881

City of San Diego
525 B Street, Suite 300
MS 906 San Diego, CA 92101
Chris Gehrki (619) 533-5312

Otay Water District
2554 Sweetwater Springs Blvd
Spring Valley, CA 91978
Richard Namba (619) 670-2730

Vallecitos Water District
201 Vallecitos De Oro
San Marcos, CA 92069
Alicia Yerman (760) 744-0460

City of Oceanside
300 North Coast Hwy
Oceanside, CA 92054
Nick Pisano (760) 435-5802

Padre Dam MWD
P.O. Box 719003
Santee, CA 92072
Maggie Buerger
619-258-4613

Vista Irrigation District
1391 Engineer St.
Vista, CA 92081
Brent Reyes (760) 597-3107

Thank you for sharing your story, inspiring others and promoting water efficient landscape designs.

Melissa and Justin Symington

California-Friendly Landscape Contest

When we read about the turf removal rebate programs offered by our water district, we knew that the time had come for us to remove the grass currently planted around our house. We had a couple of areas next to the house with grass for our dogs. However, over the course of the summer, the grass has begun to die back and looked pretty bad. We decided not to increase our irrigation use, since both of us are quite conscious of our water use, especially for landscaping. The rebate program gave us the added incentive we needed to remove the grass from our yard and redesign the areas, focusing on minimal water use and water-wise landscaping features.

We did all of the work ourselves to remove the grass and install the new landscaping—it was a fun project that took us about four months to complete. For the area at the front of our house, we chose to install a flagstone path through the landscaping, so that we could walk through the area and connect to our outdoor living space. We also wanted groundcover that didn't need to be replaced often, was porous and would hold soil moisture in for the plants, so we chose to use decomposed granite as our groundcover instead of mulch. Choosing the plants was the most fun! We visited a few local garden centers, looking for CA native and water-wise plants that complemented each other and were low maintenance. In the end, our landscape includes both CA natives and lots of succulents. One section is also our “under-the-sea” collection of succulents, all chosen because together they look like they could be part of a coral reef system.

Because of the plants we chose and the addition of DG as groundcover, we have not had to irrigate any of this area after replanting it. We do have drip irrigation installed, but we have not turned it on since converting the space two years ago. This has been a huge benefit of the installation, since we went from watering grass every other day to not irrigating at all, and we have seen our water usage decrease dramatically. Another benefit of re-landscaping our space has been the impact on local wildlife, specifically hummingbirds, butterflies and honeybees. The plants we chose are all beneficial to these species, and our front yard is frequently filled with a mix of them, all attracted to the flowers in bloom. Our turf removal has also inspired others in our neighborhood to undertake similar projects, spreading the water savings further, and we frequently chat with our neighbors about our project and how we completed all of it. Overall, the turf removal program encouraged us to undertake a project that has had quite a few benefits for us and has resulted in landscaping that is beautiful and water-wise.

Common Plant Name	Botanical Name
Euphorbia	Euphorbia rigida
Jade	Crassula ovata
Aeonium Sunburst	Aeonium decorum
Spanish Lavender	Lavandula stoechas
Blue Fescue	Festuca glauca 'Elijah Blue'
Tree aeonium	Aeonium arboreum
Blue chalk sticks	Senecio mandraliscae
Campfire	Crassula capitella
Wooly Thyme	Thymus lanuginosus
Commander Hay	Sempervivum Commander Hay
Opalina	Graptopetalum opalina
Frangipani	Plumeria rubra
Silver Teaspoon	Kalanchoe bracteata
Flapjacks Plant	Kalanchoe thyrsiflora
Hens and Chickens	Echeveria
Baby Necklace	Crassula rupestris
Swizzle Sticks	Senecio antieuphorbium
Aloe vera	Aloe vera
Blue Curls	Echeveria shaviana
Carunculata	Echeveria gibbiflora var carunculata

Pre-conversion photo(s) were submitted by customer to the Socalwatersmart turf removal rebate program and have been added to this California Friendly Landscape Contest Application.













California-Friendly Landscape Contest

Sponsored by local water agencies

CONTEST ENTRY DEADLINE: APRIL 8, 2016

Entrant's name

Entrant's daytime phone

Mark & Judy Vernoy

Property address: number and street

Entrant's e-mail address

City and zip code

Irrigation system in place and approximate irrigation schedule

yes ↑ ↓ During the summer, 10 minutes/week in most zones; 5 minutes/day in raised beds

Approximate date of landscape installation or re-landscaping project

March, 2009 (During the rainy season, we turn off all irrigation)

By signing the contest application, I authorize publication of photographs I submitted (or those taken by others) of my landscape, and my name and my address for the purpose of promoting water conservation programs.

Check here to have your address withheld from publication of results or promotional materials.

Signature of account holder

Date signed

Required materials to include with this signed application form:

- 5-10 Photos of your landscape including at least one overall view
- List of the water-wise plants in your landscape
- A copy of your water bill
- A written explanation of why you elected to install a California-friendly landscape, the design and installation process and any unsuspected benefits? **We want to hear your story!**

How did you hear about this landscape contest? (Example: Poster at a local garden and district newsletter)

Placard in a neighbor's yard

Send your application with other required materials to your servicing water agency listed below:

Note: Only these water agencies are participating in this contest.

California American Water
525 B Street, Suite 300
MS 906 San Diego, CA 92101
Chris Gehrki (619) 533-5312

Helix Water District
7811 University Ave
La Mesa, CA 91942
Ted Salois (619) 667-6257

San Dieguito Water District
160 Calle Magdalena
Encinitas, CA 92024-3721
Felice Tackthill (760) 633-2676

City of Escondido
201 North Broadway
Escondido, CA 92025
Kim Silva (760) 839-4076

Olivenhain MWD
1966 Olivenhain Road
Encinitas, CA 92024
Teresa Chase (760) 632-4641

Sweetwater Authority
P.O. Box 2328
Chula Vista, CA 91912
Clay Clifton (619) 409-6779

City of San Diego
525 B Street, Suite 300
MS 906 San Diego, CA 92101
Chris Gehrki (619) 533-5312

Otay Water District
2554 Sweetwater Springs Blvd
Spring Valley, CA 91978
Richard Namba (619) 670-2730

Vallecitos Water District
201 Vallecitos De Oro
San Marcos, CA 92069
Alicia Yerman (760) 744-0460

City of Oceanside
300 North Coast Hwy
Oceanside, CA 92054
Nick Pisano (760) 435-5802

Padre Dam MWD
P.O. Box 719003
Santee, CA 92072
Maggie Buerger
619-258-4613

Vista Irrigation District
1391 Engineer St.
Vista, CA 92081
Brent Reyes (760) 597-3107

Thank you for sharing
your story, inspiring
others and promoting
water efficient
landscape designs.

Our California-Friendly Landscape

Rationale and Design

In 2008, we began construction on a new home. Being environmentally conscious all our lives, we determined to make our new home as eco-friendly as possible. That meant using extra insulation in the walls to maintain an even house temperature, putting solar collectors on the roof to generate our own electricity, wiring the house for a future plug-in electric car (which we now have), and creating water-wise landscaping in response to living in drought-prone Southern California. We engaged a friend, John Ploetz, who happens to be a landscape designer with ample experience and lots of creative ideas for drought-tolerant landscaping. We teamed up with John to design a back yard filled with native and drought-tolerant plants; side yards with citrus and other fruit trees, along with drought-tolerant plants; a front courtyard filled with a great variety of cacti, aloes, agaves, and other succulents, as well as two Palo Verde trees; and an area inside our circular driveway filled with miscellaneous plants to accompany the two large existing California Live Oak trees, all of which complement our Southwestern-style home.

Installation

We enlisted a gardening team to do all the manual labor involved in bringing our dreams to fruition. Due to their efforts, we have sufficient drainage and irrigation throughout the entire property. In native plant areas, we use a sprinkling system; in cacti/succulent areas we use a drip system; and in our raised bed vegetable gardens we use a combination of drip irrigation and soaker hoses. To retain water and prevent excess evaporation, most of our yard is covered in mulch. In our backyard, DG pathways wind through and around the hundreds of native/drought tolerant plants and trees. These pathways are lined with rocks that in two areas are used to create dry stream bed effects. Following that theme, small boulders dot the yard to create a natural look, and boulders form a boundary along our elevated vegetable bed area. These boulders are topped with iceberg roses that, once established, have thrived with only a once a week watering. Because we felt that we needed a grassy area for our Golden Retriever and future grandchildren, we originally planted sod in our side yard; a few years later, however, we replaced this with artificial turf, which uses no water and serves our purposes perfectly. Instead of asphalt or solid concrete, we chose

pavers to cover our driveway and patios because of their bio-friendly benefit of allowing all drainage to soak directly into the ground.

Surprising Benefits

When originally designing our landscaping, our main focus was on drought tolerance. We selected plants that certainly appealed to us, but at first our main joy was in knowing that these plants would eventually require very little or no water. Now, seven years later, these plants have matured and need only minimal watering during the summer. But our greatest surprise is seeing our fully grown plants covering our entire yard with a myriad of colors, smells, and textures, from the vivid gold of the California poppy, to the pungent odor of our many salvias, to the spiky spines of our courtyard aloes. When we first put in our plants, we had no idea of the delight we would encounter from the blooming of our deep pink rockroses and light pink penstemons; our purple-hued Pride of Maderas, lavenders, butterfly bush flowers, and wild lilacs; our bright white iceberg roses and delicate bell-shaped manzanita florets; our vibrant yellow Mexican marigolds and acacia blossoms; the brilliant orange aloes and poppies; and the once-every-several-years flowered stalks of the agaves. Likewise, we never anticipated the joy we would experience as, walking along the pathways through our park-like back yard, we are attended at nearly all times of the year by the hummingbirds, crows, doves, tanagers, butterflies, bees, rabbits, and myriad other wildlife that thrive in our Southern California environment. A few years ago, while visiting in Borrego Springs and viewing the many metal sculptures along the highway created by Ricardo Breceda, we decided that his sculptures would be a welcome addition to our yard. So we now have Geraldine the Giraffe munching from the acacia tree in our backyard and Homer the Tortoise greeting guests as they enter our courtyard and approach our front door.

The pictures included with our Contest Entry and the above narrative do not do justice to our stunning, delightfully diverse landscaping enhancing our Southwestern-style home. To truly appreciate our home and garden, you need to experience it firsthand. Please drop by and wander along our meandering pathways and immerse yourself in our SoCal environment. We know you will enjoy our California-friendly landscape as much as we do.

Mark & Judy Vernoy

List of Water-Wise Plants in our Yard

SHRUBS/FLOWERS/SUCCULENTS

Arctostaphylos "Howard McMinn" (Manzanita)
Ceonothus (Wild Lilac) – several types
Various Types of Salvia
Penstemons
Leonotis leonurus (Lion's Tail)
Lavandula stoechas (Spanish Lavender)
Buddleja davidii (Butterfly Bush)
Eschscholzia californica (California Golden Poppy)
Woolly Blue Curls
Blue Hibiscus
Sunset Rockrose
Pride of Madera
Iceberg Roses
Fortnight Lily
Sea Lavender (Statice)
Blue Pickle
Mexican Marigold
Rosemary
Hardenbergia violacea "Happy Wanderer"
Sentinel Grass
Purple Fountain Grass
Matilija Poppy
Calandrinia
Grevillia
Lemonade Berry
Ribes vibrunifolium (Catalina Perfume)
Various Types of Aloes
Various Types of Agaves
Cacti
A Wide Variety of Other Succulents

TREES

Quercus agrifolia (Coast Live Oak)
Palo Verde "Desert Museum"
Tabebuja ipe (Yellow Trumpet Tree)
Jacarandas
Acacia baileyana "Purpurea"
Whitethorn Acacia
Arbutus unedo compacta (Strawberry Tree)
California Pepper Tree
Willow Pittosporum (Australian willow)



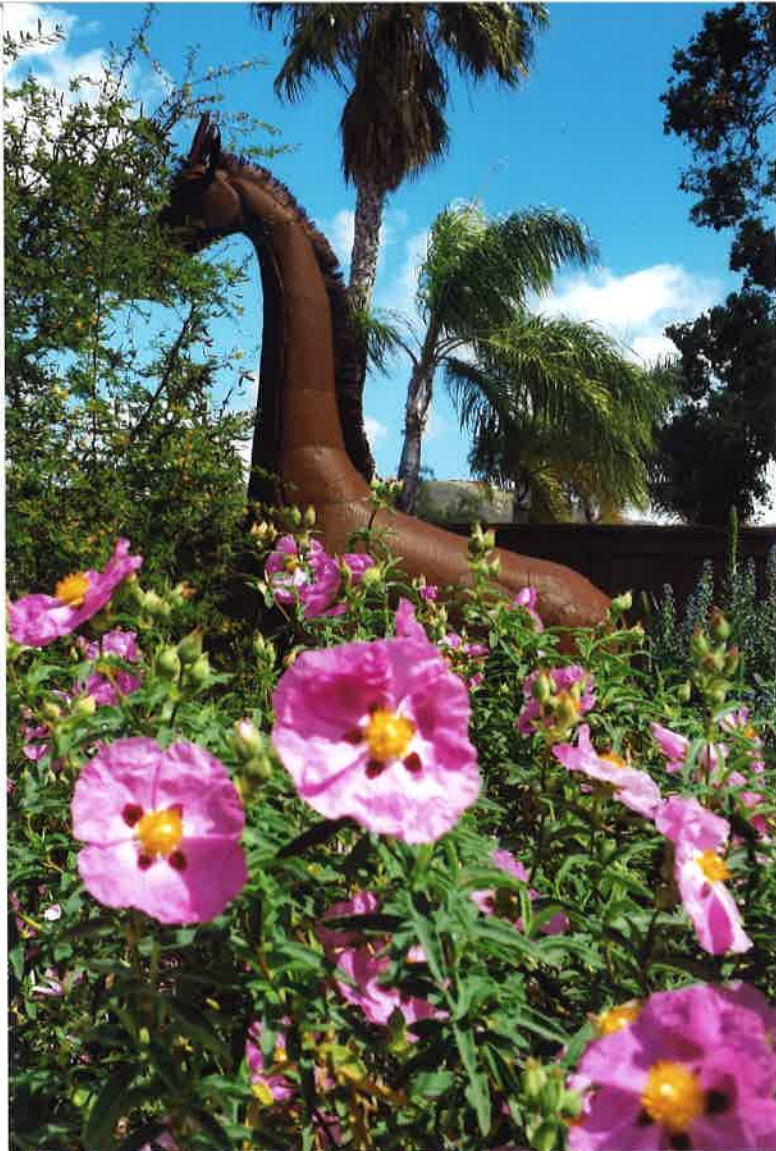









CONTEST ENTRY DEADLINE: APRIL 8, 2016

Entrant's name

Entrant's daytime phone

Jackie Weiss

Property address: number and street

Entrant's e-mail address

City and zip code

Irrigation system in place and approximate irrigation schedule

automatic sprinklers and drip irrigation for trees 2 times / week (3-4 minutes)

Approximate date of landscape installation or re-landscaping project

September 2015 through March 2016 and drought tolerant plants.

By signing the contest application, I authorize publication of photographs (submitted (or those taken by others) of my landscape, and my name and my address for the purpose of promoting water conservation programs.

Check here to have your address withheld from publication of results or promotional materials.

O.K. to publish address, J. Weiss

Jackie Weiss

4-7-16

Signature of account holder

Date signed

Required materials to include with this signed application form:

- 8-10 Photos of your landscape including at least one overall view
- List of the water-wise plants in your landscape
- A copy of your water bill
- A written explanation of why you elected to install a California-friendly landscape, the design and installation process and any unsuspected benefits? **We want to hear your story!**

How did you hear about this landscape contest? (Example: Poster at a local garden and district newsletter)

I received an email invitation to enter from VID

Send your application with other required materials to your servicing water agency listed below:

Note: Only these water agencies are participating in this contest.

California American Water
525 B Street, Suite 300
MS 906 San Diego, CA 92101
Chris Gehrki (619) 533-5312

Helix Water District
7811 University Ave
La Mesa, CA 91942
Ted Salois (619) 667-6257

San Dieguito Water District
160 Calle Magdalena
Encinitas, CA 92024-3721
Felice Tackliff (760) 633-2676

City of Escondido
201 North Broadway
Escondido, CA 92025
Kim Silva (760) 839-4076

Olivenhain MWD
1966 Olivenhain Road
Encinitas, CA 92024
Teresa Chase (760) 632-4641

Sweetwater Authority
P.O. Box 2328
Chula Vista, CA 91912
Clay Clifton (619) 409-6779

City of San Diego
525 B Street, Suite 300
MS 906 San Diego, CA 92101
Chris Gehrki (619) 533-5312

Otay Water District
2554 Sweetwater Springs Blvd
Spring Valley, CA 91978
Richard Namba (619) 670-2730

Vallecitos Water District
201 Vallecitos De Oro
San Marcos, CA 92069
Alicia Yerman (760) 744-0460

City of Oceanside
300 North Coast Hwy
Oceanside, CA 92054
Nick Pisano (760) 435-5802

Padre Dam MWD
P.O. Box 719003
Santee, CA 92072
Maggie Buerger
619-258-4613

Vista Irrigation District
1391 Engineer St.
Vista, CA 92081
Brent Reyes (760) 597-3107

Thank you for sharing your story, inspiring others and promoting water efficient landscape designs.

Water Wise Plants Used in the Landscape

Asperagus grass, Mexican grass, echeveria rosettes, agaves, aloes, ice plant

Shade trees: golden medallion, jacarandas, plum, oak

Natural materials: bark, flagstone, pebbles, cement formed stepping stones

Written Explanation of Why We Elected to Install a California Friendly Landscape

We have lived in our one acre property for thirty years. We have some lovely natural assets, like the four big oaks and two jacarandas that spread their arms in a canopy in the backyard. They offer shade and cool the breeze during the summer.

In 1986 we originally used sod around the house, seeded the rest of the acre with grass, and covered the slopes with ice plant and ivy. Then, we added a pool.

As the draught years began to be more numerous, we decided to add more trees to give shade around the house. In June 2015, I applied for a So Cal Water Smart "Turf Removal" grant. The grant got us thinking about eliminating not only grass, but ice plant as well.

One of our neighbors also has large areas to landscape. He used a bark mixture of juniper and eucalyptus that smelled very nice. We had his gardener deliver three truck loads for us. Deciding to use bark, flagstone, pebbles, and cement stepping stones on multiple levels, we developed new areas of the yard. Four more jacarandas, a golden medallion, and a plum tree were added for shade, and fifteen succulents added color and variety to the sunny areas. Retaining walls were added to reinforce the small patios on the slopes. And, as our yard became more draught tolerant and protected from erosion, it also became more visually interesting, as one can witness from the photographs.

Jackie and Gabriel Weiss



Pre-conversion photo(s) were submitted by customer to the Socalwatersmart turf removal rebate program and have been added to this California Friendly Landscape Contest Application.

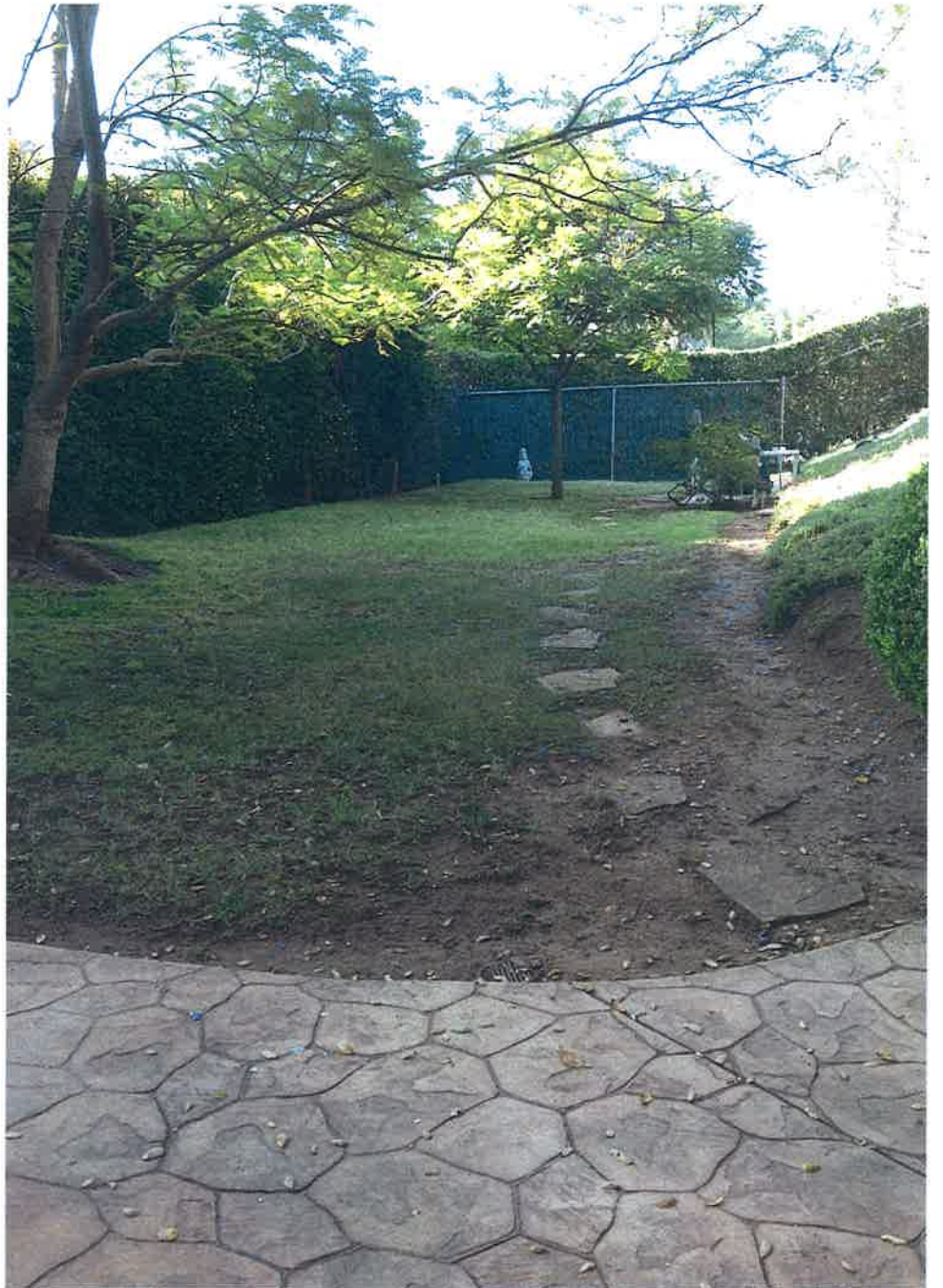



Waves - backyard



Veria - backyard



Weiss - backyard

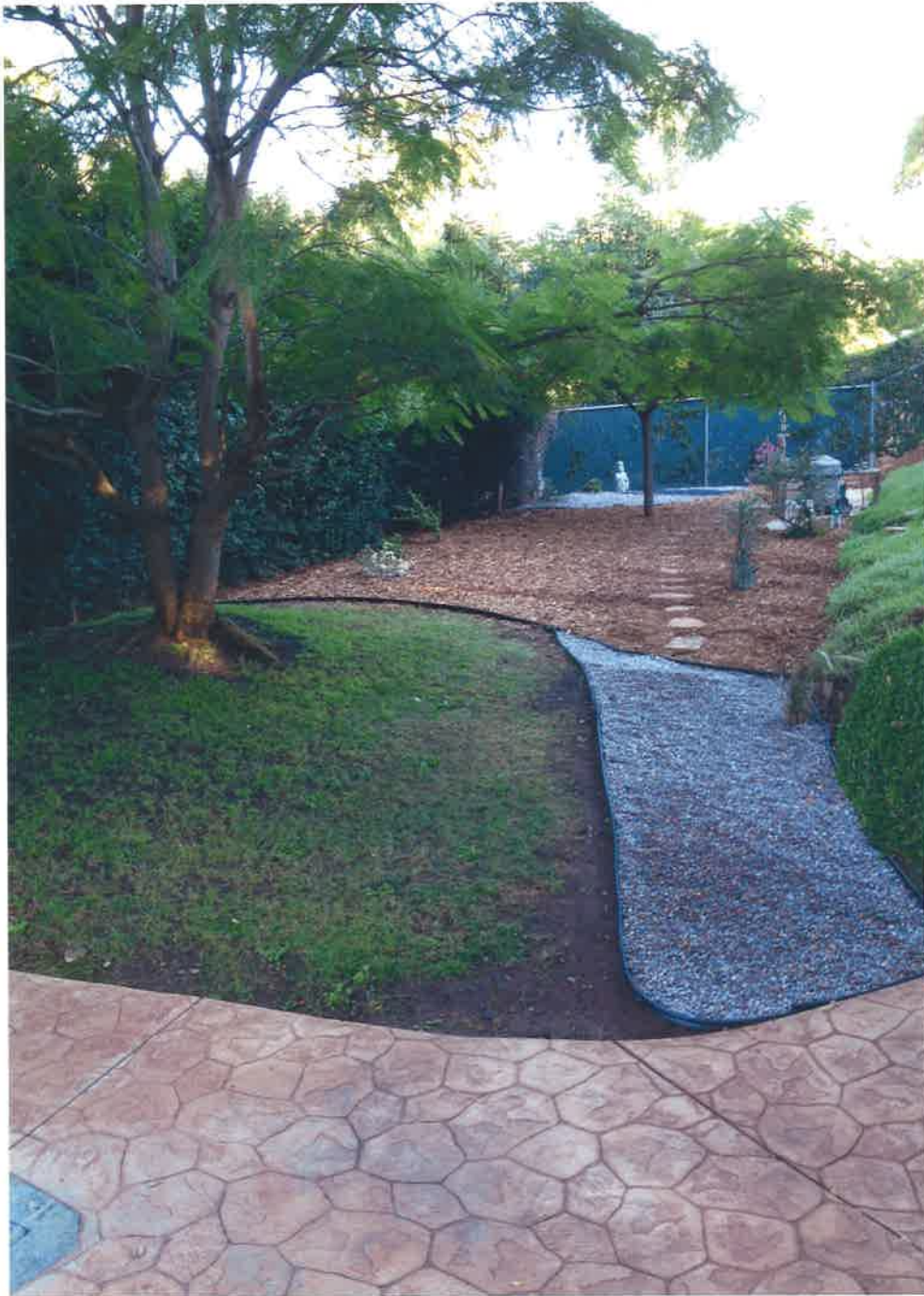

Weiss - backyard



Moana - Backyard



Neira - backyard



Mina's - backyard



Weiss - backyard



Weiss - front yard

California-Friendly Landscape Contest

Sponsored by local water agencies

CONTEST ENTRY DEADLINE: APRIL 8, 2016

Entrant's name

Duane Weston

Entrant's daytime phone

Property address: number and street

613 Cortez Ave

Entrant's e-mail address

City and zip code

Irrigation system in place and approximate irrigation schedule

Spray system and irrigate 2-3 times a week

Approximate date of landscape installation or re-landscaping project

August - September 2015

By signing the contest application, I authorize publication of photographs I submitted (or those taken by others) of my landscape, and my name and my address for the purpose of promoting water conservation programs.

Check here to have your address withheld from publication of results or promotional materials.

Duane Weston

Signature of account holder

3/30/16

Date signed

Required materials to include with this signed application form:

- 5-10 Photos of your landscape including at least one overall view
- List of the water-wise plants in your landscape
- A copy of your water bill
- A written explanation of why you elected to install a California-friendly landscape, the design and installation process and any unsuspected benefits? **We want to hear your story!**

How did you hear about this landscape contest? (Example: Poster at a local garden and district newsletter)

VID email and district website

Send your application with other required materials to your servicing water agency listed below:

Note: Only these water agencies are participating in this contest.

California American Water
525 B Street, Suite 300
MS 906 San Diego, CA 92101
Chris Gehrki (619) 533-5312

Helix Water District
7811 University Ave
La Mesa, CA 91942
Ted Salois (619) 667-6257

San Dieguito Water District
160 Calle Magdalena
Encinitas, CA 92024-3721
Felice Tackill (760) 633-2676

City of Escondido
201 North Broadway
Escondido, CA 92025
Kim Silva (760) 839-4076

Olivenhain MWD
1966 Olivenhain Road
Encinitas, CA 92024
Teresa Chase (760) 632-4641

Sweetwater Authority
P.O. Box 2328
Chula Vista, CA 91912
Clay Clifton (619) 409-6779

City of San Diego
525 B Street, Suite 300
MS 906 San Diego, CA 92101
Chris Gehrki (619) 533-5312

Otay Water District
2554 Sweetwater Springs Blvd
Spring Valley, CA 91978
Richard Namba (619) 670-2730

Vallecitos Water District
201 Vallecitos De Oro
San Marcos, CA 92069
Alicia Yerman (760) 744-0460

City of Oceanside
300 North Coast Hwy
Oceanside, CA 92054
Nick Pisano (760) 435-5802

Padre Dam MWD
P.O. Box 719003
Santee, CA 92072
Maggie Buerger
619-258-4613

Vista Irrigation District
1391 Engineer St.
Vista, CA 92081
Brent Reyes (760) 597-3107

Thank you for sharing
your story, inspiring
others and promoting
water efficient
landscape designs.

Why I Installed a California-friendly Landscape!

I had been aware of the increasing water shortage in California for quite some time and other than turning off the tap when I brushed my teeth, had done little on my part. As I noticed yards in our area turning to artificial turf and gravel, I knew that was NOT how I wanted my yard to look BUT I did want to save water. I began researching online and met with a designer who understood my desire to conserve water while maintaining a beautiful yard.

We worked together to choose drought tolerant, blooming plants and designed an area with a bench to increase the time spent in the front yard. We discussed lighting and the addition of stairs to tie the look together. After some initial scepticism from my husband, we decided to apply for the landscaping rebate and began plans to tear out 20 years of lawn.

We did the demolition ourselves and hired a contractor to install concrete, a new irrigation system, lighting and new, beautiful drought tolerant plants. Of course the planting coincided with probably the hottest September on record! After losing a few plants the weather cooled off and we were able to complete our project in time to apply for the rebate.

Fast forward six months and we LOVE our new landscaping. Not only has it greatly reduced our water usage, it is also almost maintenance free and looks beautiful! We receive many compliments from neighbors and have even encouraged a few to move away from turf. My favorite part is the way the plants sway in the breeze, exactly the movement I was looking for. And an unexpected benefit is we are spending more time in our front yard, sitting on our bench, enjoying the beautiful view.

Sue Weston

Weston Plant List

Rosa "Flower Carpet white	5 gallon	x5
Raphiolepis umbellata minor	5 gallon	x5
salvia leucantha	5 gallon	x3
Olea "Little Ollie"	5 gallon	x1
salvia "hot lips	5 gallon	x6
erigeron karvinskianus	3 gallon	x8
lantana montevidensis "alba"	5 gallon	x4
lomandra "breeze"	5 gallon	x2
Olea "Swan Hill"	24" box	x1
Lithodora Grace ward	1 gallon	x6
Correa dusky bells	1 gallon	x9
cistus "sunset"	1 gallon	x6

Pre-conversion photo(s) were submitted by customer to the Socalwatersmart turf removal rebate program and have been added to this California Friendly Landscape Contest Application.



WESTON -



WESTON -

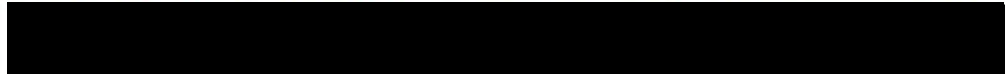



STAFF REPORT

Agenda Item: 10

Board Meeting Date: May 11, 2016
Prepared By: Lisa Soto
Approved By: Roy Coox

SUBJECT: RECOGNITION IN SPECIAL DISTRICT GOVERNANCE

RECOMMENDATION: Receive the Special District Leadership Foundation's (SDLF) Gold Recognition in Special District Governance for the Vista Irrigation District, and the SDLF Recognition in Special District Governance for Directors Randy Reznicek and Marty Miller, to be presented by Chris Palmer, Southern California Field Representative for the California Special Districts Association.

PRIOR BOARD ACTION: None.

FISCAL IMPACT: A processing fee of \$130.

SUMMARY: The Recognition in Special District Governance was designed by the Special District Leadership Foundation (SDLF) to honor special district board members, and is comprised of two distinct parts: the completion of the Special District Leadership Academy (Academy) and 10 hours of continuing education. The Special District Leadership Academy is a curriculum-based continuing education program that recognizes the necessity for the board and general manager to work closely toward a common goal. The Academy provides the knowledge base to perform essential governance responsibilities.

SDLF also offers levels of recognition to honor districts. Vista Irrigation District currently holds a "Silver Recognition", which means that the majority of the District's board members have received Recognition in Special District Governance. With Directors Miller and Reznicek now having completed the Academy, all five VID Board members, including Directors Vasquez, MacKenzie and Dorey, have received Recognition in Special District Governance, and therefore Mr. Palmer will also be presenting the District with its Gold Recognition at this meeting.

DETAILED REPORT: The SDLF is an independent, non-profit organization formed to promote good governance and best practices among California's special districts through certification, accreditation and other recognition programs. The SDLF and its activities are supported by the California Special Districts Association. The Special District Leadership Academy is comprised of four courses: Governance Foundations, Setting Direction/Community Leadership, Board's Role in Human Resources and Board's Role in Finance and Fiscal Accountability. The four courses are unique from any other courses on special district governance in that they are curriculum that has been created by special districts and agreed upon as what governing officials of special districts should know.



STAFF REPORT

Agenda Item: 11

Board Meeting Date: May 11, 2016
Prepared By: Eldon Boone, Brian Smith,
Don Smith
Approved By: Roy Coox

SUBJECT: DIVISION REPORTS

RECOMMENDATION: Note and file informational report.

PRIOR BOARD ACTION: None.

FISCAL IMPACT: None.

SUMMARY: Previous month's and anticipated activities are reported by each division.

ADMINISTRATION DIVISION

April

- The District's total water production for March 2016 was 1,187 acre-feet (AF) compared to 1,343 AF in 2013, representing a 12 percent decrease. **For the ten month period ending March 31, 2016, the District's total water production has decreased by 20 percent when compared to the same nine month period in 2013, which exceeds our State mandated conservation standard of 12%.**
- Hosted Homeowner Landscape Makeover Workshop.
- Continued testing content management system and developing content for the District's new website.
- Continued coordinating the development of the District Budget.
- Coordinated training on proper use of respiratory protection equipment and fit testing for field personnel.
- Attended the Meet ACWA's President event held at the San Diego County Water Authority.

May

- Attend Association of California Water Agencies 2016 Spring Conference.
- Mail notice regarding the availability of the Consumer Confidence Report (annual water quality report) on-line beginning July 1, 2016 with water bills.
- Participate in Vista Strawberry Festival.
- Issue news releases announcing the winners of the scholarship, water awareness poster and landscape contests.
- Continue coordinating the development of the District Budget.
- Coordinate first aid, cardiopulmonary resuscitation (CPR) and automated external defibrillator (AED) training for District personnel.

ENGINEERING DIVISION

April

- Continued working on design of main replacement projects. Began development of project guidelines for outsourcing the design and construction of additional replacement projects.
- AB Line and Meyer's Siphon Replacement Projects – Infrastructure Engineering Corporation, (IEC) continued on design efforts.
- Attended meeting of the North County Recycled Coalition.
- Flume Relocation (Hidden Valley Estates) - Continued working with Shea Homes regarding Reimbursement Agreement for relocation of a portion of the flume as part of the Hidden Valley Estates project. Continued review of flume relocation plans and easement documents. Shea continued grading operations on the development site that started in March. Shea also selected a contractor for their wet utilities, and requested an additional bid from them for the flume relocation work.
- Finalized and issued Request for Proposal (RFP) for update of the District's Master Plan.
- Helix Environmental began preparation of Historic American Engineering Record (HAER)-level documentation of the Vista Flume, including archival quality photographs and associated documentation to be filed with appropriate historical societies and archives.
- Met with Richard Brady and Associates to discuss preparation of a condition assessment of HP reservoir.

May

- Mainline Replacement Projects in design (current projects): Penview Dr. (NIP), Private Road off Buena Creek Rd. (NIP), Tower Dr. (NIP), Las Flores Dr., Taylor St. (NIP), Goodwin Dr. (NIP), Private Roads off Mar Vista Dr. (NIP), Alley north of Orange St. (NIP), Hilo Dr. (NIP), Quails Trails (NIP), Peach Grove Lane (NIP).
- Mainline Replacement Projects in planning (future projects): Mar Vista Dr., Miramar Dr., Marine View Dr., E. Vista Way, Mason Rd., Lado De Loma, Eddy Dr., Camino Patricia, Camino Corto, Nordahl Rd. (NIP), HN Line- Gopher Canyon to Fairview Dr., N. Citrus, Nevada Ave., Lemon Ave., Buena Creek Rd. (NIP), Vista Grande Dr. (NIP) Green Hills Way, Elevado Road, Via Christina, S. Santa Fe Pipeline, Rancho Vista Rd., Bandini Place, McGavran Dr., Ora Avo Dr., Shale Rock, San Clemente Ave. (NIP), Primrose Ave., La Mirada, Crescent Dr., Descanso Ave., Pump Station No. 10 By-Pass – Blue Bird Canyon.
- AB Line and Meyers Siphon Projects – IEC to continue with final design.
- City of Vista Projects: Paseo Santa Fe Streetscape Improvements - Phase II along South Santa Fe. from Ocean View Drive to Terrace Drive - coordinate design of water improvements associated with City street improvements.
- Flume Relocation (Hidden Valley Estates) - Complete recordation of required easements and finalize Reimbursement Agreement for presentation to Board for approval of project. Continue review of flume relocation plans and specifications. Evaluate potential construction contracting strategies, including hiring the contractor Shea selected for their wet utilities.
- Attend meeting of the North County Recycled Coalition.
- Receive proposals from consultants for preparation of an update to the District's Master Plan.
- Develop and issue RFP for on-call engineering services for water pipeline replacements.

* (NIP) = Nipponite pipe

FIELD SERVICES AND WATER RESOURCES DIVISION

**VID Water Production
March 2016**

Description	Current Month Production		Average Production of Last 12 Months		Total, Fiscal Year-to-Date
	(mgd)	(af)	(mgd)	(af)	(af)
VID's EVWTP Water Production					
Local Water	0.00	0.00	1.32	124.18	1,062.60
SDCWA Raw Water	11.11	1,057.20	7.77	726.18	6,487.20
Subtotal (EVWTP Water Production)	11.11	1,057.20	9.09	850.36	7,549.80
Oceanside Contract Water	0.94	89.10	3.70	346.38	2,752.40
SDCWA Treated Water	0.43	40.80	1.15	106.68	1,111.00
TOTAL WATER PRODUCTION	12.48	1,187.10	13.94	1,303.41	11,413.20

Lake Henshaw and Warner Ranch Wellfield statistics are summarized as follows:

Lake Henshaw

Storage as of May 2, 2016: 5,772 af (11% of 51,774 af capacity)
 Current releases: 0 cfs
 Change in storage for month of March: 404 af (gain)
 Total releases for month of March: 0 af
 Hydrologic year-to-date rain total: 20.63 inches (May 2, 2016)
 Percent of yearly average rain: 84% (30-year average: 24.45 inches)
 Percent of year-to-date average rain: 87% (30-year average through April: 23.74 in.)

Warner Ranch Wellfield

Number of wells running in March: 15
 Total production for month of March: 581 af
 Average depth to water table (April): 118 ft (see attached historical water table chart)

**Electrical Energy Use at VID Headquarters
March 2016**

Description	Current Month Production	Average of Last 12 Months	Total, Fiscal Year-to-Date
	(kWh)	(kWh)	(kWh)
Solar Production (\$0.1565 per kWh)	37,978	35,080	296,588
Additional Commercial Use (\$0.04977 per kWh)	5,753	15,268	168,031
TOTAL ELECTRICAL ENERGY USE	43,731	50,348	464,619

April

- Repaired one main, four fire hydrant and three service leaks. Replaced ten valves and installed two service laterals.
- Replaced 81 meters.
- Continued weed abatement at various facilities and the flume utilizing conservation camp crews.

- Utility Service Group completed the epoxy coating of the interior of E1 reservoir. The reservoir was inspected, disinfected and returned to service.
- Started main line replacement of Nipponite pipe on Buena Creek Road (private easement) – 1,120’ of 8” PVC, six services and one hydrant. Approximately 25% complete.
- Started main line replacement of AC (350’ is Nipponite) on Tower Drive – 1,000’ of 8” PVC, 14 services and one hydrant. Approximately 10% complete.
- Completed main line replacement of AC pipe on Greenbush Lane (work performed for developer) – 320’ of 8” PVC and one hydrant.
- Completed main line replacement of Nipponite pipe on Penview Drive – 700’ of 4” and 500’ of 8” PVC, 14 services and one hydrant.
- Regulators – preventive maintenance was performed on one system regulator.
- SCADA – converted hardware and radio communications at E32 regulator, San Luis Rey reservoir, and VID # 11 to an Ethernet based platform.
- Replaced control wiring and enhanced altitude valve control at San Luis Rey reservoir.
- Station # 10 – removed pump and motor # 1 for refurbishment.
- Station # 12 – installed and conducted performance testing on refurbished pump and motor # 1.
- Analyzed 100 routine (reportable to SWRCB) bacteriological samples. All samples were negative for total coliforms (TC-). The average chlorine residual for April was 2.59 mg/L.
- Inspected and tested 32 new backflow devices that were integrated into the District’s cross-connection control program.
- Shutdown HL main to install 24” inline valve and upgraded two auto air vents.
- WQ Calls/Incidents for April – received five discolored water calls. Two calls were private issues and the other three were related to a hit fire hydrant.
- Submitted a request to the SWRCB to be exempted from the special lead and copper monitoring requirements imposed on public water systems receiving desalinated seawater based upon an expectation that less than 5 percent of the water delivered to the District will consist of desalinated seawater during the sampling period.
- Re-routed driveway to employee housing at Henshaw.
- Measured the area of tamarisk removal completed this year using forces of the Puerta La Cruz Honor Camp – 34 acres.
- Used Hidden Valley Pump Systems to pull the pump at well 8A; began well rehabilitation.

May

- Continue main line replacement projects on Tower Drive and Buena Creek Road.
- Begin internal recruitment for Welder/Equipment Operator.
- Start main line replacement on alley north of Orange Street – replace 200’ of 6” Nipponite pipe.
- Install and conduct performance testing on refurbished pump # 2 at Station # 10.
- Finish Consumer Confidence Report data compilation and submit draft to SWRCB.
- Collect second quarter Stage 2 Trihalomethane/Haloacetic acid samples.

WARNER RANCH, SAN LUIS REY RIVER, FERC and ESCONDIDO ISSUES

- At the invitation of the Department of Water Resources (DWR), District Staff attended a DWR informational meeting with Tribal entities to discuss groundwater management practices and possible collaboration and/or coordination regarding elements of the Sustainable Groundwater Management Act (SGMA).
- Conducted the annual Board tour of the Warner Ranch, including a visit of the Vista Flume and the Escondido/Vista Water Treatment Plant.

- Entry permits to the Warner Ranch were issued to:
 - California Regional Water Quality Control Board, the US Forest Service, and the CDFW in order to cross District lands to survey those portions of the West Fork of the San Luis Rey River that lie in the Cleveland National Forest;
 - Moss Landing Marine Laboratories to conduct investigations for USEPA's National Wetlands Condition Assessment;
 - Chambers Group Inc., doing environmental studies for SDG&E in advance of their wood-to-steel replacement project, Tie-Line 682;
 - US Geological Survey for arroyo toad surveys and bullfrog eradication under contract with the US Navy for RTSWS;
 - A group of about 10 Boston College alumni to visit Eagle Rock.
- Cattle counts for February: Hettinga – 2,767 Mendenhall – 99
- See the attached report on activity for February 2016 for the Lake Henshaw Resort, Inc. and the chart of Water Table Depth.

ATTACHMENTS:

Lake Henshaw Resort, Inc., Activity Reports – February 29, 2016

VID's Warner Wellfield - Water Table Depth vs. Monthly Wellfield Production



**LAKE HENSHAW RESORT, INC.
ACTIVITY REPORT
AS OF FEBRUARY 29, 2016**

	2015 Feb	2015 Mar	2015 Apr	2015 May	2015 Jun	2015 Jul	2015 Aug	2015 Sep	2015 Oct	2015 Nov	2015 Dec	2016 Jan	2016 Feb	12 MO AVG
Fishing Permits	233	370	608	639	770	706	736	475	255	192	141	234	327	437
Boat Launches	7	12	32	38	54	15	15	9	4	0	2	4	9	15
Motor Boats (full day rental)	26	27	48	47	68	48	54	23	7	14	156	14	13	42
Motor Boats (half day rental)	1	4	10	11	8	13	8	2	1	1	40	1	6	8
Campground/Head Count	284	515	651	1,423	869	2,364	1,445	1,927	510	328	158	130	170	829
Campground/Cars, Trucks, etc.	78	143	162	419	258	666	410	574	152	93	37	17	58	236
Campground/Recreational Vehicles	3	14	8	14	22	11	1	12	12	9	6	3	5	9
Mobile Home/Spaces	62	62	63	61	61	60	60	61	61	61	61	61	61	61
M.H.P. Daily (Visitors/Head Count)	108	100	112	126	142	130	126	135	108	93	87	44	9	102
M.H.P. (Residents/Head Count)	88	89	89	93	93	90	90	91	91	91	94	85	85	90
Storage	5	5	5	7	7	7	7	7	7	6	5	4	4	6
Cabins	94	197	185	158	176	193	219	188	192	167	12	79	91	150
Hunters	0	0	0	0	0	0	0	0	0	19	83	88	0	15

*The figure of 19 for "Hunters," in the month of November, is due to the public purchasing permits.
Z:\Water Resources\DATA\Henshaw\RESORT\Resort Sum 2009-present.xls

VID's Warner Wellfield

Water Table Depth vs. Monthly Wellfield Production

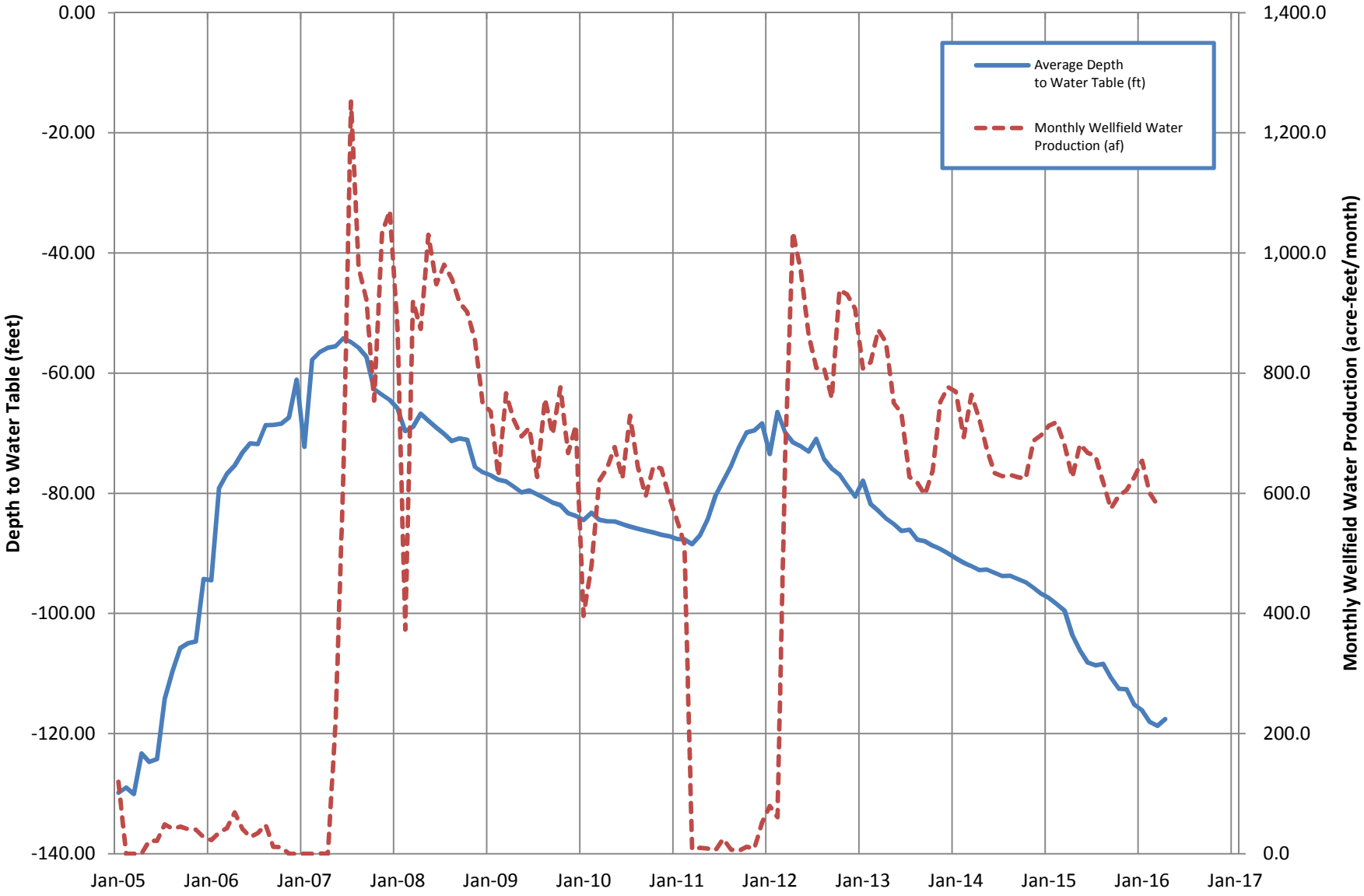



STAFF REPORT

Agenda Item: 12

Board Meeting Date:	May 11, 2016
Prepared By:	Brett Hodgkiss
Reviewed By:	Eldon Boone
Approved By:	Roy Coox

SUBJECT: DISTRICT WEBSITE

RECOMMENDATION: Review District's new website.

PRIOR BOARD ACTION:

11/03/15 The Board provided input on the look, feel and functionality of District's new website.

01/06/16 The Board provided feedback on the conceptual designs of District's new website.

FISCAL IMPACT: The website design consulting effort cost \$23,100.

SUMMARY: The Board held a workshop on November 3, 2015 to discuss the design and development of the District's new website. The workshop provided the consultant, Digital Deployment, with an opportunity to receive input from Directors regarding the desired look, feel and functionality of the new website. The Board members discussed what they would like to see in the new website, emphasizing the need for the site to be customer-friendly and easy to navigate.

Based on feedback received from the Board and staff, Digital Deployment developed two conceptual designs (with two different color schemes for each design) for the District's new website which were presented to the Board at their January 6, 2016 meeting. The Board members commented on each design and advised staff (and Digital Deployment who joined the meeting via conference call) of their preferred alternative. After hearing which design the Board preferred, staff and Digital Deployment began working on developing the new website.

DETAILED REPORT: Over the past few months, Digital Deployment refined the design based on input received in January and migrated information from the District's existing website to the new website. Recently, administrative staff has had an opportunity to test the content management system as well as add/edit content which is much simpler to do than on the District's existing website. Additionally, departmental staff has had an opportunity to review and provide feedback on the new website, which has been both helpful and positive.

At this time, staff would like to provide the Board with an opportunity to see the new website before making it available to our customers and the public at-large (possibly in June). It is important to note that this is a starting point with the new website; over time, the site will evolve as staff adds/changes content to keep the site current and enhance its usability.



STAFF REPORT

Agenda Item: 13

Board Meeting Date:	May 11, 2016
Prepared By:	Randy Whitmann
Reviewed By:	Brian Smith
Approved By:	Roy Coox

SUBJECT: HP RESERVOIR STRUCTURAL EVALUATION

RECOMMENDATION: Authorize the General Manager to enter into an Agreement for Professional Services with Richard Brady & Associates for the HP Reservoir Structural Evaluation for a cost not to exceed \$75,000.

PRIOR BOARD ACTION: None.

FISCAL IMPACT: The proposed \$75,000 contract consists of evaluating the extent of the upgrades that are necessary to repair the tank along with associated costs and recommendations for project delivery. Preliminary cost estimates to complete the repairs and necessary upgrades to meet structural/seismic codes are on the order of \$2.5-\$3.0 million, while the cost for constructing a new reservoir is estimated to be over \$5.0 million.

SUMMARY: The HP Reservoir is a 5 million gallon (MG), pre-stressed concrete tank constructed in the early 1960s. This reservoir is located near the end of Edgehill Road as shown on the attached map. Recently, exterior concrete spalling was found near the base of the tank, exposing the steel pre-stressing cables with some detached from the wall and laying on the ground (see photos attached). After a site visit with the consultant, it was recommended that the tank be drained and scheduled for immediate evaluation and repair.

DETAILED REPORT: Staff, accompanied by Richard Brady and his structural engineer, Max Dykmans, visited the tank site on Friday April 29, 2016. After reviewing the spalled area, it was noted that the black steel wire used and installation methods common in the 1960s, were sometimes susceptible to corrosion. After visual and sound testing the lower perimeter of the tank exterior, it was evident that other areas could be experiencing similar corrosion. One option would be to conduct thorough testing and only repair the wiring that needs it, but mobilization of the cable wrapping equipment would likely contribute to the majority of the repair costs. Therefore, the most appropriate economical fix for the tank appears to be removal of all the gunite and existing wire wrap, sandblast the exterior wall, apply new galvanized wire strand, and provide a shotcrete cover over the new strand.

With immediate exterior repairs in order, the existing tank's conformance to current structural/seismic codes also needs to be evaluated. Additionally, the interior and other appurtenances should be inspected for potential repair work or recommended upgrades, with the project in its entirety also being compared to constructing a new tank.

The proposed contract with the consultant is for the Phase 1 project evaluation and development, to evaluate the existing HP Reservoir and provide a recommended approach and delivery method for construction that will provide the District with the best value solution. Key Phase 1 tasks include:

1. Review existing design for compliance with current structural and seismic design codes.
2. Perform a geotechnical investigation to obtain site specific design criteria.
3. Perform a visual inspection on the reservoir interior floor, wall and roof, and perform the following tests:

- Evaluate the condition of any observed concrete cracking or spalling, particularly in areas where there may be exposed rebar. Mark and photograph non-hairline cracks (wide enough to stick a dime in) using NSF 61-approved paint.
 - Evaluate the condition of expansion joints and sealants.
 - Evaluate the condition of all appurtenances and compliance with standards, including overflow piping, inlet and outlet piping, drains, and ladders.
4. Perform an investigation of the roof and roofing material to confirm the absence of asbestos and other possible hazardous materials.
 5. Assess the extent of interior corrosion.
 6. Perform a seismic/structural code check of all structural components including floors, walls, columns, roofs, and the entire tank lid including all entry portals. Determine whether the reservoir meets current civil, structural, and seismic design standards as applicable to the design and/or retrofit of potable water storage reservoirs.
 7. Develop preliminary cost estimates for the anticipated work, that at this time will most likely include the following major items:
 - Remove the existing exterior gunite coating.
 - Remove the existing wire strand.
 - Sand blast the reservoir exterior.
 - Remove the existing wood framed roof.
 - Install a new exterior footing to allow the placement of seismic cables.
 - Apply the new pre-stressing strand.
 - Apply the shotcrete cover over the prestressing strand.
 - Install a new aluminum dome cover.
 - Repair internal cracks and spalling.
 - Repair appurtenances as necessary.
 - Install new external stairs (by others).
 8. Meet to discuss project delivery options.

ATTACHMENTS: Vicinity Map



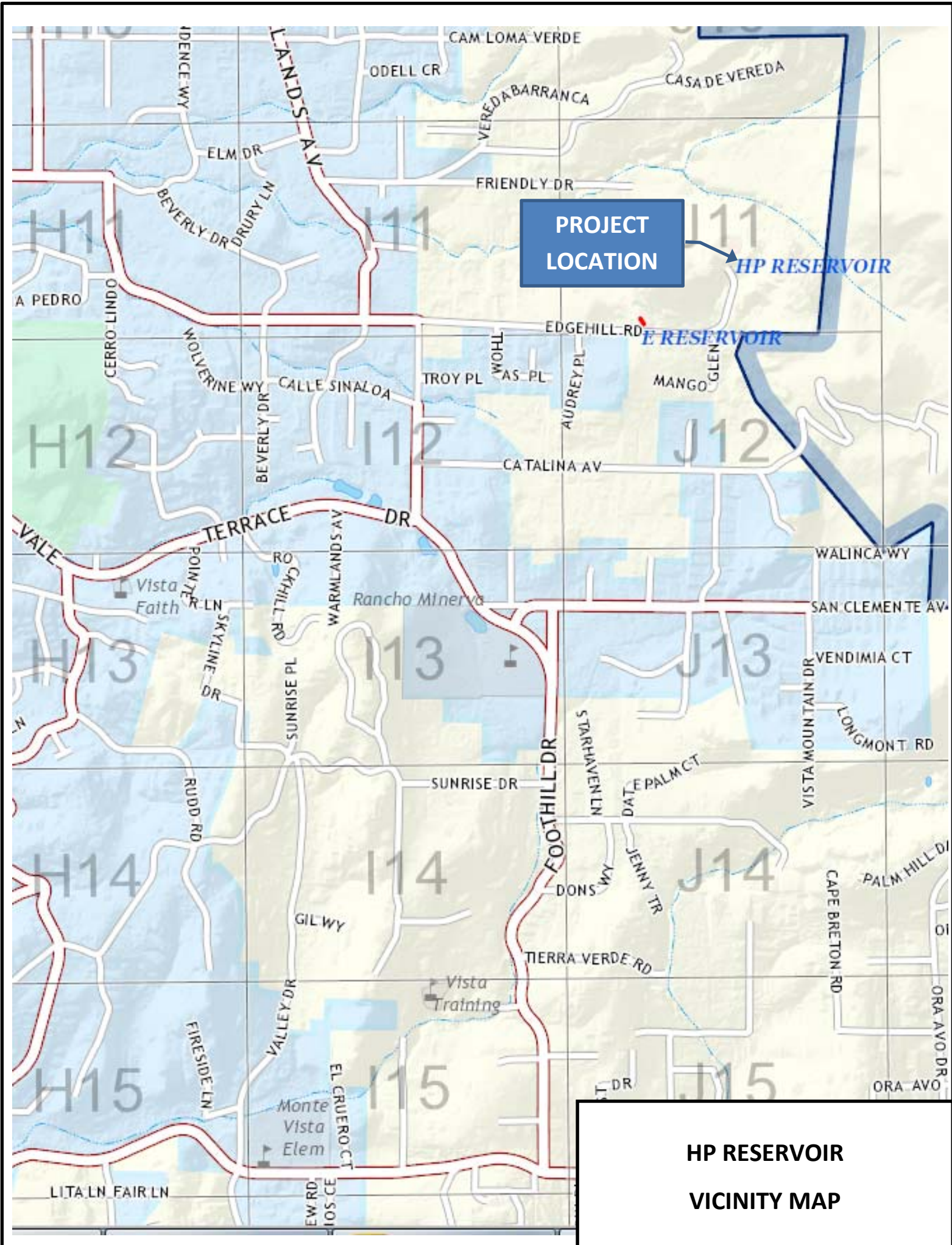

**PROJECT
LOCATION**

HP RESERVOIR

E RESERVOIR

**HP RESERVOIR
VICINITY MAP**



STAFF REPORT

Board Meeting Date: May 11, 2016
Prepared By: Brian Smith
Approved By: Roy Coox

SUBJECT: MAIN REPLACEMENT PROGRAM UPDATE

RECOMMENDATION: For informational purposes.

PRIOR BOARD ACTION: Since Fiscal Year 1996, the Board has allocated \$20 million in various capital outlay budgets for the Main Replacement Program.

5/1/2002 Received update on the Main Replacement Program
6/18/2014 Received update on the Main Replacement Program

FISCAL IMPACT: None for this item. The FY 2016 Capital Budget includes \$1.5 million for the Main Replacement Program (Budget #16-03).

SUMMARY: In 1995, the Board established funding for an ongoing program to replace aging water mains throughout the distribution system. The goal of this program has been to replace pipelines before they reach the end of their useful life and become a maintenance liability, and to replace pipelines due to street realignments and/or improvements.

Since the inception of the Main Replacement Program, more than 26 miles of pipe have been replaced, ranging in size from 2 inches to 20 inches. Additionally, approximately 10 miles of mains have been replaced in conjunction with other capital improvement projects including the C-Line Replacement Project, N. Santa Fe Widening Project, E-Line Replacement Project, S. Santa Fe Improvement Projects and various other smaller projects.

DETAILED REPORT: Approximately 150 miles of the District's over 400 miles of mains were installed prior to 1970. These 150 miles of pipeline are comprised of approximately 52 miles of various types of steel pipe and 98 miles of Asbestos Cement (AC) pipe. Attached is a map showing the location and age breakdown of these mains throughout the District. Also attached is a chart showing the type of pipe remaining in the distribution system by decade of installation.

District Crews responded to 27 mainline leaks last year, which equates to about 6 breaks per 100 miles of pipe. In comparison, a Water Research Foundation survey cited a national average of 25 breaks per 100 miles per year. Three of these leaks were on a specific brand of AC pipe, known as Nipponite, which was installed in the 1960's. Breaks on this pipe can be more catastrophic than other brands of AC pipe or steel pipe, which can and has led to more extensive property damage. District crews have replaced over 4 miles of Nipponite and there are approximately 12 miles of Nipponite pipe remaining in the distribution system. Replacement of this pipe is currently the top priority of the main replacement program. In order to accelerate replacement of the Nipponite pipe, staff is investigating outsourcing the design and construction of some of the pipeline projects in the next fiscal year.

As part of the upcoming Master Plan Update, staff is requesting consultants to develop a strategy for assessing the condition and estimated life expectancy of District pipelines. This assessment will hopefully aid staff in prioritizing main replacements in the future.

ATTACHMENTS: Map of Pipeline Installations by Decade
Type of Pipe in Current System by Decade Installed
Map of AC Nipponite mains

VISTA IRRIGATION DISTRICT PIPELINE INSTALLATIONS BY DECADE

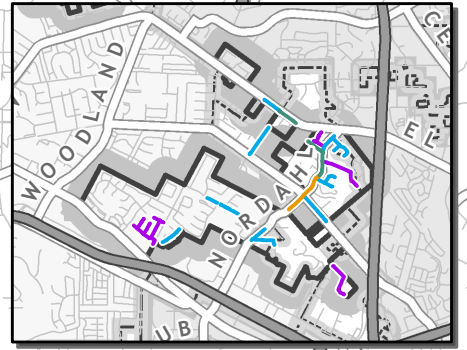
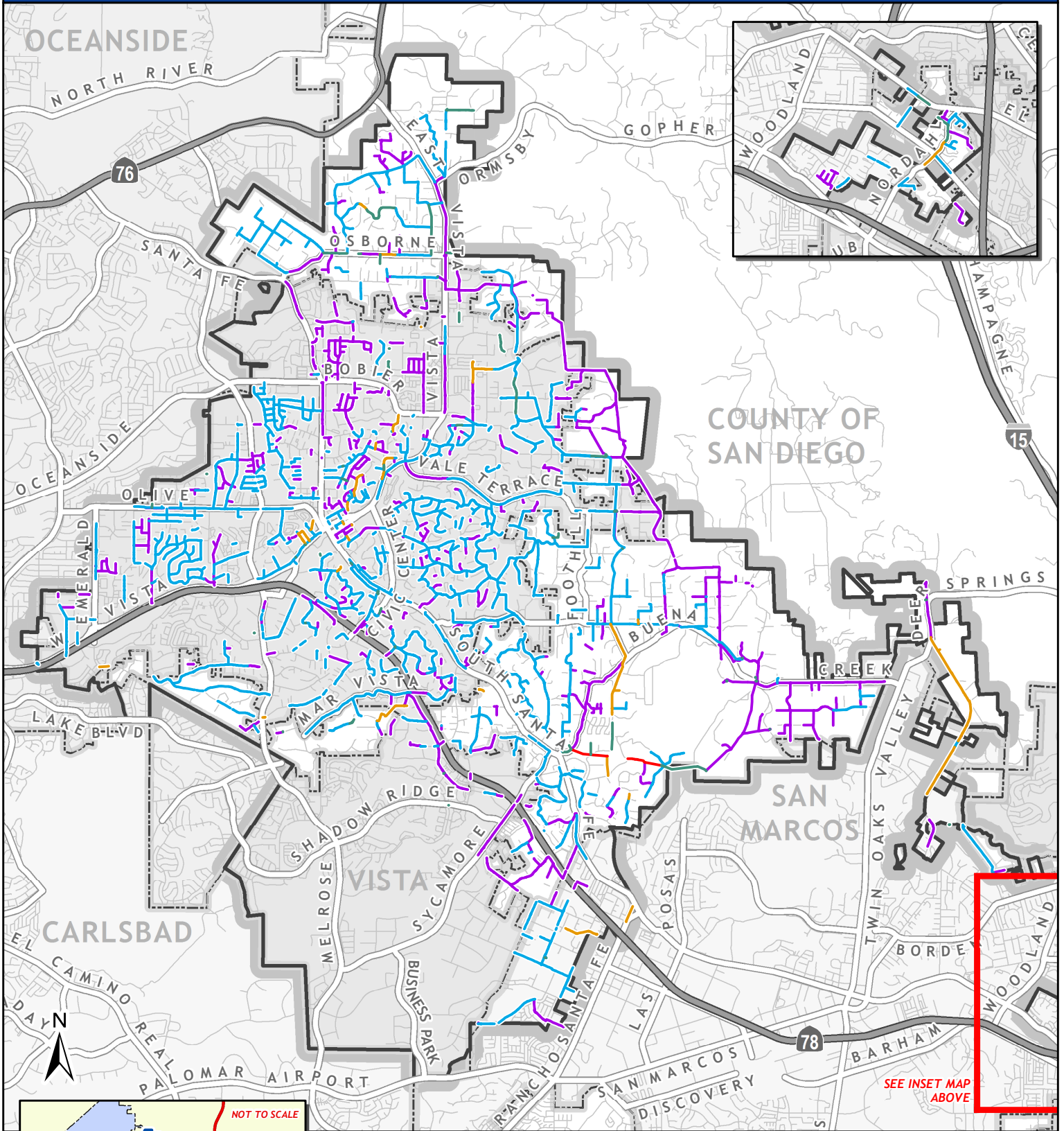

Pipeline Installation Periods

- ~ Unknown
 - ~ 1931-1940
 - ~ 1941-1950
 - ~ 1951-1960
 - ~ 1961-1970
- VID BOUNDARY
 VALID AS OF 4/13/2016



Scale 1:75,000

DISCLAIMER: The Vista Irrigation District makes no representation or warranties regarding the accuracy of this map nor the data from which the map was derived. The Vista Irrigation District shall not be liable under any circumstances for any direct, indirect, special, incidental or consequential damages with respect to any claim by any user or any third party on account of or arising from the use of this map.

NOTE: GIS data derived, modified, reduced, and/or processed from SanGIS/SANDAG downloadable data - www.sangis.org



TYPE OF PIPE IN CURRENT SYSTEM BY DECADE INSTALLED

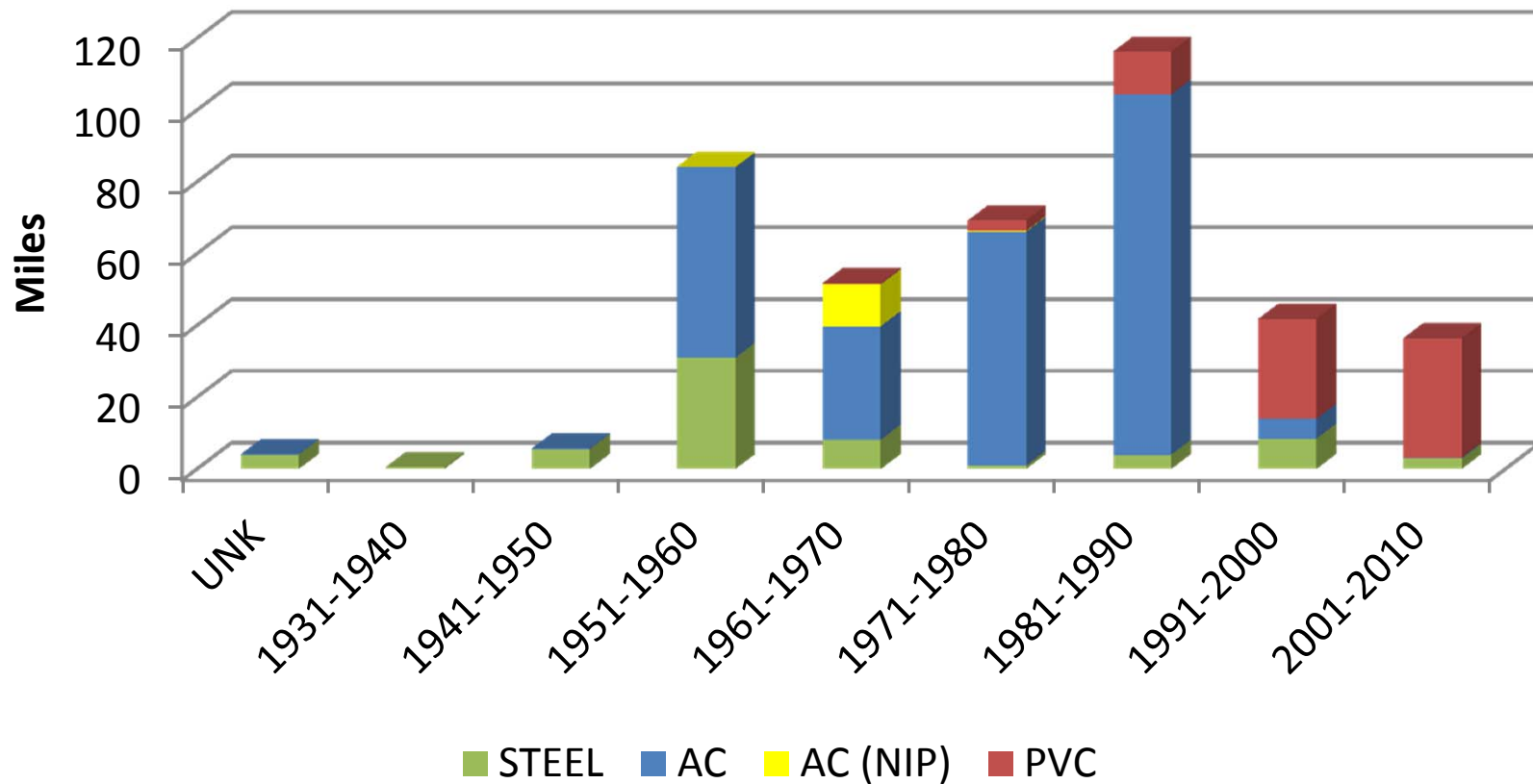

VISTA IRRIGATION DISTRICT NIPPONITE PIPELINES

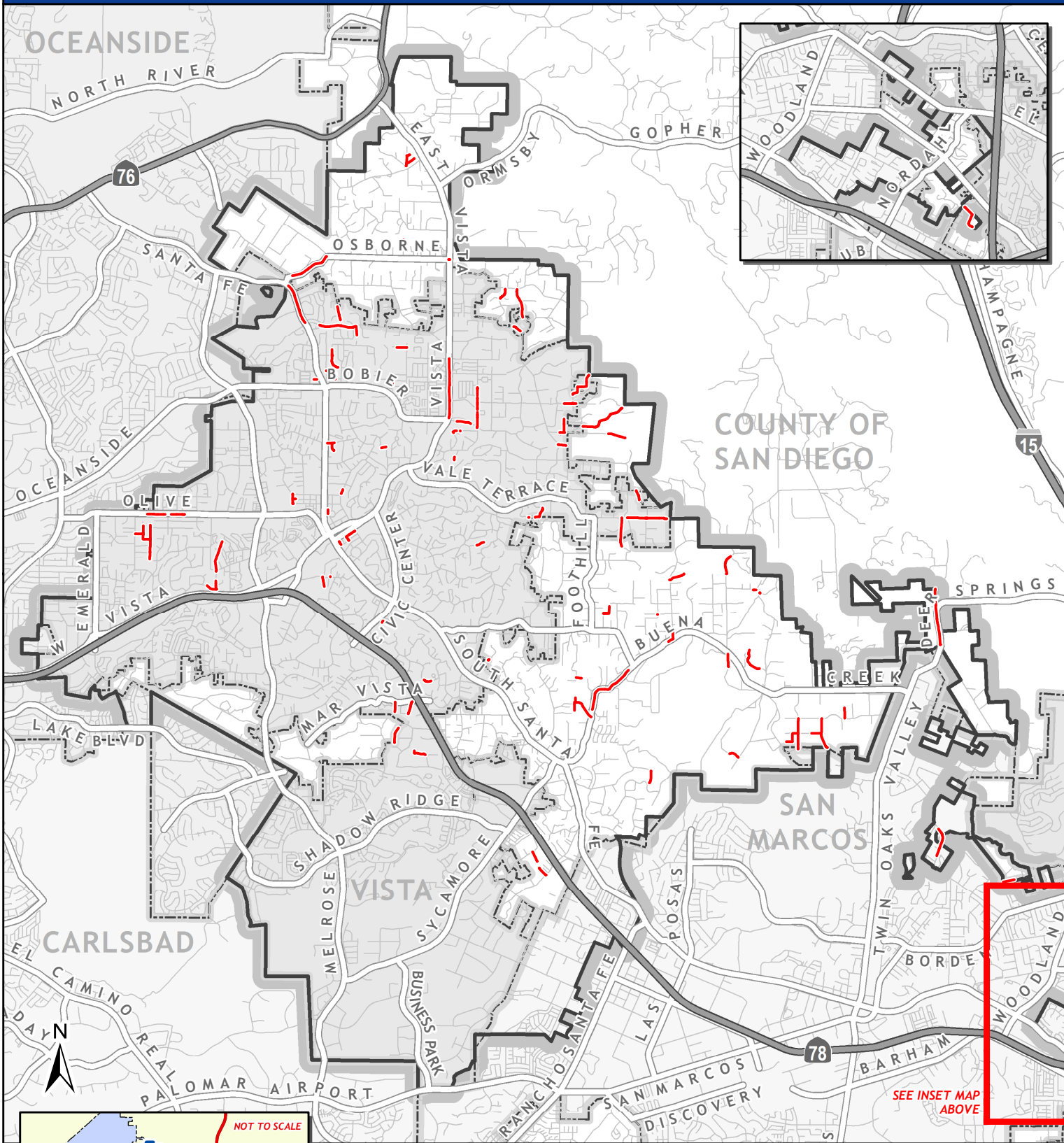

SEE INSET MAP ABOVE

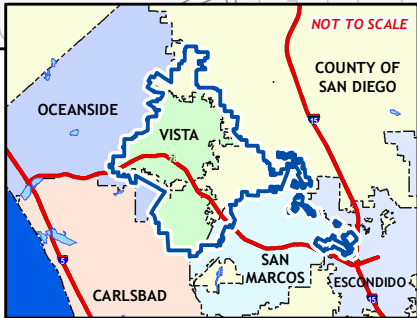

 Nipponite Pipelines  VID BOUNDARY VALID AS OF 4/13/2016



Scale 1:75,000

DISCLAIMER: The Vista Irrigation District makes no representation or warranties regarding the accuracy of this map nor the data from which the map was derived. The Vista Irrigation District shall not be liable under any circumstances for any direct, indirect, special, incidental or consequential damages with respect to any claim by any user or any third party on account of or arising from the use of this map.

NOTE: GIS data derived, modified, reduced, and/or processed from SanGIS/SANDAG downloadable data - www.sangis.org





STAFF REPORT

Board Meeting Date: May 11, 2016
Prepared By: Brian Smith
Approved By: Roy Coox

SUBJECT: GRANT OF NONEXCLUSIVE EASEMENT

RECOMMENDATION: That the Board accept Grant of Nonexclusive Easement No. FS38 (Modified) for a 30-foot easement over property owned by Shea Homes Limited Partnership (Shea) located north of Vista Verde Drive, Escondido (LN-2015-003, APN 224-100-12, 57, 58, 59 & 60).

PRIOR BOARD ACTION:

- 7/10/13 Authorized staff to proceed with rehabilitation improvements to the Flume as recommended in the Black and Veatch report.
- 6/3/15 Board approved the concept of relocating a portion of the Flume, authorized staff to begin cost sharing negotiations with Shea and directed staff to bring the item back to the Board in closed session to discuss property transaction considerations.
- 6/17/15, 7/1/15, 7/15/15 and 8/5/15: Closed session discussions regarding price and terms.

FISCAL IMPACT: None for this action. Current estimated construction costs for relocation of the Flume range between \$1.4 and \$2.0 million. Under the terms of the proposed Reimbursement Agreement for the Flume relocation, Shea will pay for the first \$800,000 of the project costs and the District will pay the next \$600,000. Project costs beyond \$1.4 million will be shared equally between both parties.

SUMMARY: Shea is pursuing the development of a 179 lot residential subdivision adjacent to a portion of the Vista Flume, including sections known as Baumgartner Bench and Little Tunnel. The development, Canyon Grove Estates (formerly Hidden Valley Estates), is located north of Vista Verde Drive in the City of Escondido. The District and Shea have determined that relocating the Flume to an underground pipeline through the project is mutually beneficial, and have agreed to share in the relocation costs through a Reimbursement Agreement. The City of Escondido has accepted all of the street rights of way within the development, and Board acceptance of this Grant of Nonexclusive Easement document will provide all of the necessary public rights of way required to allow relocation of the Flume. Final approval of the Flume relocation project and the Reimbursement Agreement with Shea will be brought to the Board for consideration at a future Board Meeting.

DETAILED REPORT: The Grant of Nonexclusive Easement document is a modification of the District's standard easement language at the request of Shea. The modifications, which have been reviewed by District Legal Counsel, include clarification that the easement is nonexclusive while protecting the District's rights within the easement.

The Flume relocation project appears to qualify for a statutory exemption under CEQA if all of the rights-of-way are in place prior to approval of the project. Therefore, the Reimbursement Agreement and project approval will be brought to the Board for consideration at a subsequent Board meeting.

Last summer, the Board authorized staff to negotiate a Reimbursement Agreement with Shea for relocation of the Flume utilizing the following basic terms:

1. Shea will pay for the design of the Flume relocation and the District will review and approve the plans and specifications.
2. District will contract for the construction work per the approved plans including: General Contractor, Staking & Survey, Soils Engineer, and any District/3rd party inspections needed.
3. Shea will provide management support for the bidding process, with District oversight, including: General Contractor, Staking & Survey, and Soils Engineer.
4. Shea will contribute the first \$800K to the District to be put towards the Flume relocation. The District will contribute the next \$600K.
5. Should costs exceed the initial contributions of \$1.4 million, Shea and the District will split the additional costs 50/50.
6. Shea will provide oversight/management support to the District in overseeing the District selected contractors during the construction of the new Flume facility.
7. Shea will coordinate preparation of the as-builts between the contractor and engineers, and provide final as-built mylars.

Design of the Flume relocation is currently in the plan check phase. Infrastructure Engineering Corporation (IEC) has been retained to provide plan review in addition to review by appropriate staff members. IEC is currently designing the Meyers Siphon Replacement Project, which has many similarities to this project.

Shea has begun grading operations and anticipates the site will be to a point that the new Flume pipeline can begin construction in the summer of this year.

ATTACHMENTS: Grant of Nonexclusive Easement No. FS38 (Modified)
Map of proposed relocation

REQUESTED BY AND RETURN TO:

**VISTA IRRIGATION DISTRICT
1391 ENGINEER STREET
VISTA, CA 92081-8836**

**This Document benefits the District
No Fee—Public Agency
Documentary Transfer Tax \$ -0-
Parcel No. _____**

Vista Irrigation District

**GRANT OF NONEXCLUSIVE EASEMENT
(FS38-Modified)**

SHEA HOMES LIMITED PARTNERSHIP, a California limited partnership, as “Grantor”, for and in consideration of the sum of One Dollar and other valuable consideration paid by VISTA IRRIGATION DISTRICT, as “Grantee”, receipt whereof is hereby acknowledged, does hereby grant to Grantee its successors and assigns, a nonexclusive easement (“Easement”) in, upon, under and across the Easement Area (defined below), to erect, construct, reconstruct, replace, repair, maintain and use a subterranean pipeline for the purpose of water transmission (“Pipe”), together with reasonably necessary fixtures and appurtenances at such locations and elevations, upon, along, over and under the Easement Area as Grantee may now or hereafter deem convenient and necessary from time to time, together with the right of reasonable ingress thereto and egress therefrom, to and along the Easement Area by a practical route or routes in, upon, over and across the hereinafter described lands, together with the right to clear and keep clear the Easement Area from explosives, buildings and structures, invasive trees and other materials or growths detrimental to the uses granted herein.

The easement being granted lies within the following described land:

PARCEL 1 (Fee Title Property):

That certain real property described in Exhibit A attached hereto and made a part hereof (“Grantor Property”).

PARCEL 2: (Easement Area)

Said Easement located within the Grantor Property is more particularly described in Exhibit B, and shown and delineated on Exhibit C, attached hereto and made a part hereof (“Easement Area”).

Grantor and successors in estate shall not erect or construct, or permit to be erected or constructed, any buildings, or other structure, or any other improvements, or drill any well or wells, within the limits of the Easement Area which would prevent Grantee’s use of the Easement, without the prior written consent of Grantee, which shall not be unreasonably withheld, conditioned or delayed.

Grantee shall have the right to maintain and use gates in all fences which now cross or shall hereafter cross the Easement Area, and to trim and cut and clear away any trees and brush whenever in its judgment the same shall be necessary for the convenient and safe exercise of the rights hereby granted. The right to convey, transfer, and assign the Easement in whole or in part to others is hereby granted to the Grantee, provided the assignment is made in writing.

Grantee agrees that the Easement granted herein is not exclusive, and Grantee agrees that Grantor may grant other future easements on, under or over the Easement Area, with the consent of Grantee, which consent shall not be unreasonably withheld provided, however, Grantee's consent is not required in connection with future easements granted to a homeowners association relating to the Grantor Property or to its members. Notwithstanding the foregoing, no such other future easements (whether Grantee's consent is required or not) may prevent or significantly impair Grantee's ability to construct, operate, maintain, repair, replace and inspect that portion of the Pipe within the Easement Area, or impair the physical and structural integrity of, or reasonable access to, such portion of the Pipe. In this regard, the rights granted pursuant to this Easement shall be deemed to be superior to the rights granted in any subsequent easements on, under or over the Easement Area for any other utilities or facilities, and Grantee accordingly shall not be responsible for paying the cost of relocation of the Pipe or any other utilities installed in the Easement Area in the event of any utility conflicts.

It is also understood and agreed by the parties hereto that the Grantor and successors or assigns, shall not increase, decrease or permit to be increased or decreased, the existing ground elevations of the Easement Area existing at the time the Pipe becomes fully operational, without the prior written consent of the Grantee, which shall not be unreasonably withheld, conditioned or delayed.

In exercising the Easement, should it become necessary for Grantee to remove or demolish any improvements built, or planted on said easement, (i) except for pavement consisting of asphaltic concrete, the cost of such removal or demolition and replacement of such removal incurred by the Grantee shall be at the cost and expense of Grantor, and (ii) Grantee shall use reasonable efforts not to destroy or damage any such improvements, plants or landscaping (the intent of Grantee and Grantor being to minimize the cost and expense to Grantor for its restoration of the removed improvements, plants and landscaping). If in using the Easement, Grantee removes dirt or changes the ground elevation, Grantee shall be responsible for returning the Easement Area to the same ground elevations existing prior to such removal or change.

Grantee and Grantor agree that any conveyance of the Grantor Property (or any portion thereof) will relieve the transferring Grantor of any further obligations and liabilities under this Grant of Nonexclusive Easement (or under the portion of the Grantor Property transferred) arising from and after the date of such conveyance of the Grantor Property (or portion thereof), and that from and after the date of such conveyance of the Grantor Property (or portion thereof), the transferee Grantor will be automatically obligated and liable under this Grant of Nonexclusive Easement (or under the portion of the Grantor Property transferred). Further, Grantee agrees that Grantor may transfer any obligations under this Grant of Nonexclusive Easement to a homeowners association established to govern and maintain the Grantor Property.

Grantee agrees that if Grantor subdivides the Grantor Property, this Grant of Nonexclusive Easement will be deemed quitclaimed as to each resulting lot or parcel from such subdivision if the resulting lot or parcel does not contain any portion of the Easement Area.

Except for Grantor's or any of its members, directors, officers, employees, attorneys, consultants, representatives, successors and assigns (collectively, "Grantor-Related Parties") negligence or willful misconduct, neither Grantor nor any Grantor-Related Party shall be liable for any loss, damage or injury whatsoever to the person or property of any person or entity whatsoever, including but not limited to Grantee or any employee, agent, contractor, guest or invitee of Grantee, in any way resulting from or arising out of Grantee's use of the Easement or Pipe, or directly or indirectly from any state or condition of the Easement or Pipe. In addition, except for Grantor's or any Grantor-Related Party's negligence or willful misconduct, Grantee shall indemnify, defend and hold Grantor and each of the Grantor-Related Parties harmless from and against any and all actions, claims, demands, judgments, attorneys' fees, costs, damages to person or property, penalties, obligations, expenses or liabilities of any kind that may be asserted or claimed by any person or entity in any way arising out of or in connection with Grantee's use of the Easement or Pipe, or directly or indirectly from any state or condition of the Easement or Pipe, or any part thereof. In connection therewith, if Grantee is obligated to indemnify, defend and hold Grantor and each of the Grantor-Related Parties harmless pursuant to the preceding sentence: (a) Grantee shall defend any action(s) or proceeding(s) filed in connection with any of said claims, damages, penalties, obligations or liabilities and shall pay all costs and expenses, including attorneys' fees, incurred in connection therewith; (b) Grantee shall promptly pay any judgment or decree rendered against Grantor or any Grantor-Related Party covering such claims, damages, penalties, obligations or liabilities, and Grantee shall save and hold Grantor and all Grantor-Related Parties harmless therefrom; and (c) in

the event Grantor or any Grantor-Related Party is made a party to any action or proceeding filed or prosecuted for such damages, penalties, obligations, or liabilities, Grantee shall pay to Grantor any and all costs and expenses incurred by Grantor in such action or proceeding, together with reasonable attorneys' fees.

Except for the negligence or willful misconduct of Grantee or any of its directors, officers, employees, attorneys, consultants, representatives, successors and assigns (collectively, "Grantee-Related Parties"), Grantor shall indemnify, defend and hold Grantee and each of the Grantee-Related Parties harmless from and against any and all actions, claims, demands, judgments, attorneys' fees, costs, damages to person or property, penalties, obligations, expenses or liabilities of any kind that may be asserted or claimed by any person or entity in any way arising out of or in connection with any damage or injury to the Pipe or the Easement Area caused directly or indirectly by Grantor or any Grantor-Related Party. In connection therewith, if Grantor is obligated to indemnify, defend and hold Grantee or any of the Grantee-Related Parties harmless pursuant to the preceding sentence: (a) Grantor shall defend any action(s) or proceeding(s) filed in connection with any of said claims, damages, penalties, obligations or liabilities and shall pay all costs and expenses, including attorneys' fees, incurred in connection therewith; (b) Grantor shall promptly pay any judgment or decree rendered against Grantee or any Grantee-Related Party covering such claims, damages, penalties, obligations or liabilities, and Grantor shall save and hold Grantee and all Grantee-Related Parties harmless therefrom; and (c) in the event Grantee or any Grantee-Related Party is made a party to any action or proceeding filed or prosecuted for such damages, penalties, obligations, or liabilities, Grantor shall pay to Grantee any and all costs and expenses incurred by Grantee in such action or proceeding, together with reasonable attorneys' fees.

The Easement conveyed hereby is conveyed subject to all covenants, conditions, restrictions, easements, reservations, dedications and other encumbrances of record.

Grantor:

Dated: _____

SHEA HOMES LIMITED PARTNERSHIP, a California limited partnership

By _____
Title _____

By _____
Title _____

SECTION ONE:

FOR VISTA IRRIGATION DISTRICT USE ONLY

This is to certify that the interest in real property conveyed by easement

dated _____ from _____

to Vista Irrigation District, a political subdivision, is hereby accepted by

order of the Board of Directors of said District on _____, and the Grantee consents to the recordation thereof by its duly authorized officer.

Secretary
Board of Directors
VISTA IRRIGATION DISTRICT

LEGEND:

- P.O.C. POINT OF BEGINNING
- T.P.O.B. TRUE POINT OF BEGINNING
- P.O.T. POINT OF TERMINUS
- C.O.C. CERTIFICATE OF COMPLIANCE
- () RECORD DATA PER NOTED REFERENCE

EXHIBIT "B"

SHEET 1 OF 1

PARCEL A
C.O.C. 2011-0176093

PARCEL C
C.O.C. 2011-0176095
APN: 224-100-82

PARCEL B
C.O.C. 2011-0176094
APN: 224-100-83

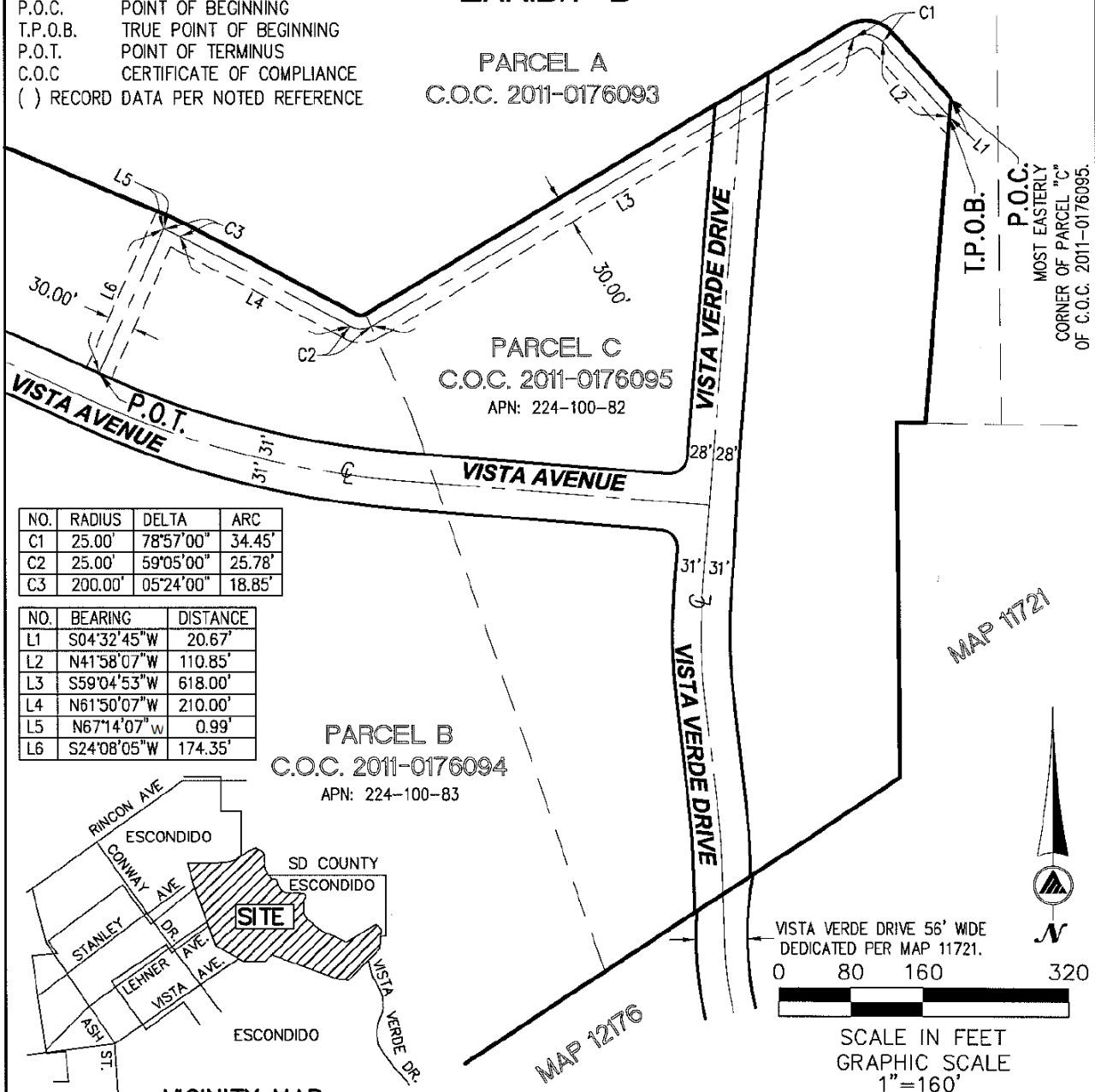

NO.	RADIUS	DELTA	ARC
C1	25.00'	78°57'00"	34.45'
C2	25.00'	59°05'00"	25.78'
C3	200.00'	05°24'00"	18.85'

NO.	BEARING	DISTANCE
L1	S04°32'45"W	20.67'
L2	N41°58'07"W	110.85'
L3	S59°04'53"W	618.00'
L4	N61°50'07"W	210.00'
L5	N67°14'07"W	0.99'
L6	S24°08'05"W	174.35'

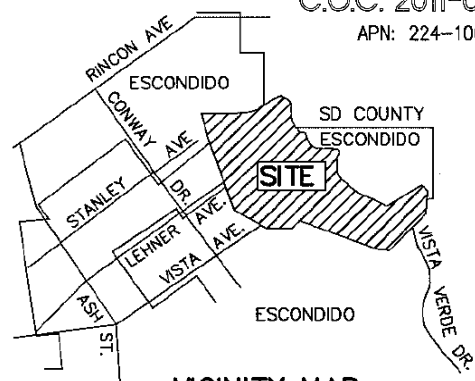

VICINITY MAP
NO SCALE

THIS PLAT WAS PREPARED BY
ME OR UNDER MY DIRECTION.

DOUGLAS W. MASSON, R.C.E. 17706

MASSON & ASSOCIATES, INC.
Planning • Engineering • Surveying
Solved.
200 E. Washington Ave., Suite 200
Escondido, CA 92025
O. 760.741.3570
F. 760.741.1786
www.masson-assoc.com



VISTA IRRIGATION DISTRICT

GRANT OF RIGHT-OF-WAY (FS38)
SHEA HOMES LIMITED PARTNERSHIP

APN: 224-100-82 & 83		T.B.:
SCALE: 1" = 160'		L.N.
APPD. BY	DATE	W.O.
DRAWN BY : RMM	DATE: 02/12/16	
SHEET 1 OF 1	MAP:	

PATH: I:\14\14132\PROD\Mapping\Legals & Plats\14132VID-Ease.dwg

HIDDEN VALLEY T.M. - TRACT NO. 932

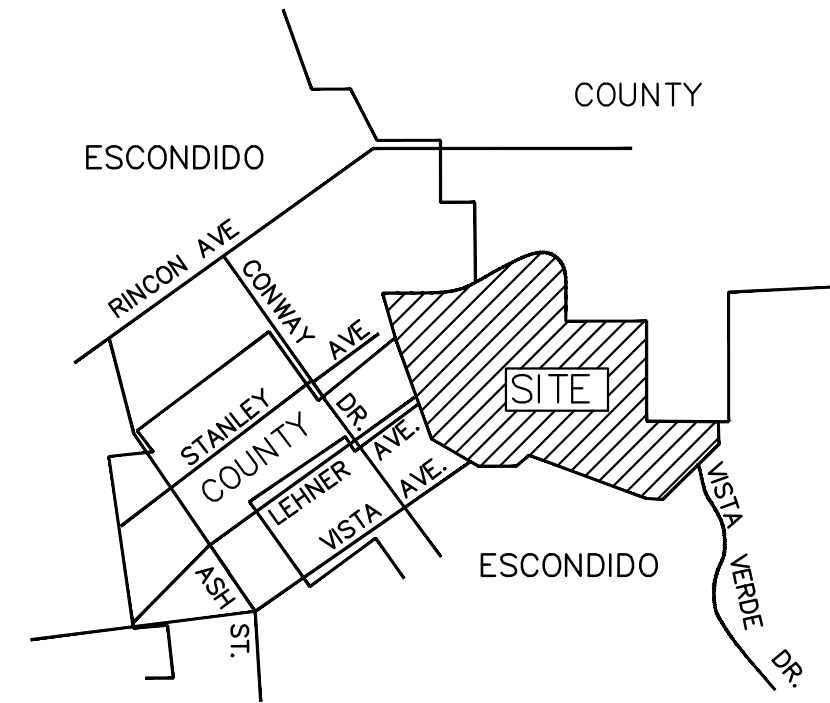

VICINITY MAP
NO SCALE TB 1109 J4, 1110 A4

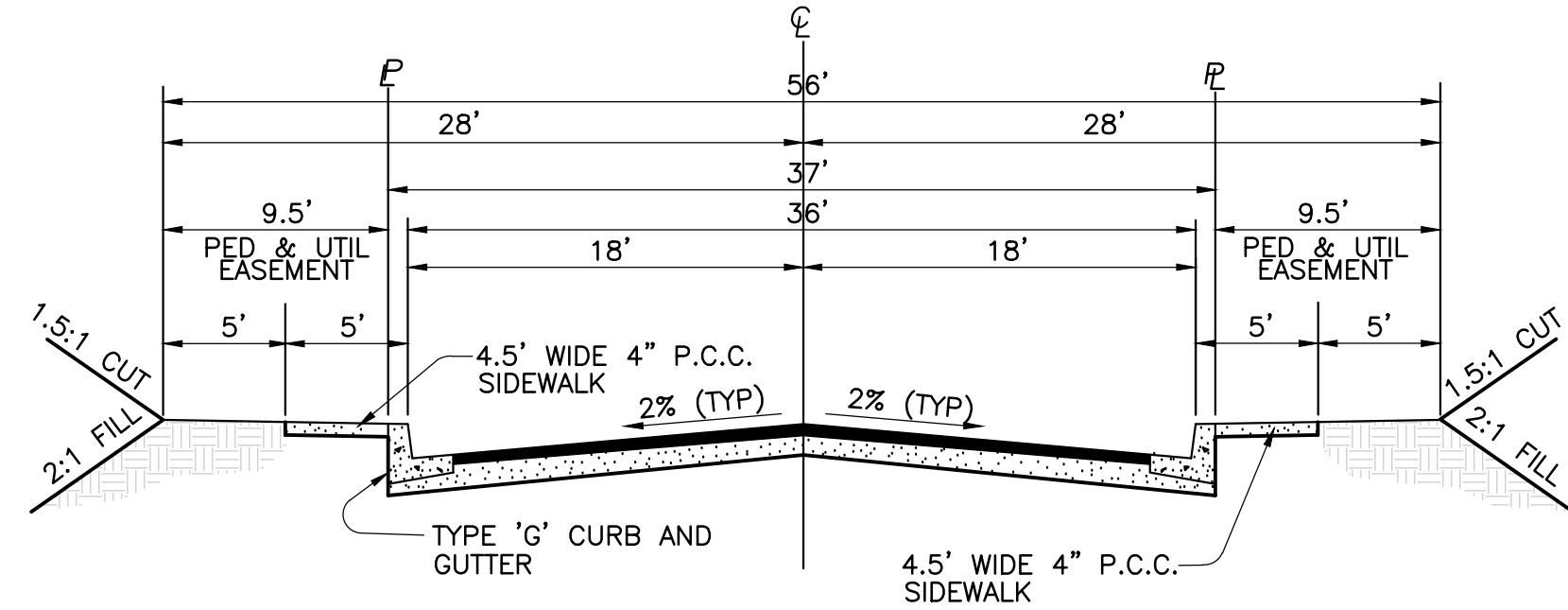

TYPICAL SECTION - PRIVATE STREETS
NO SCALE

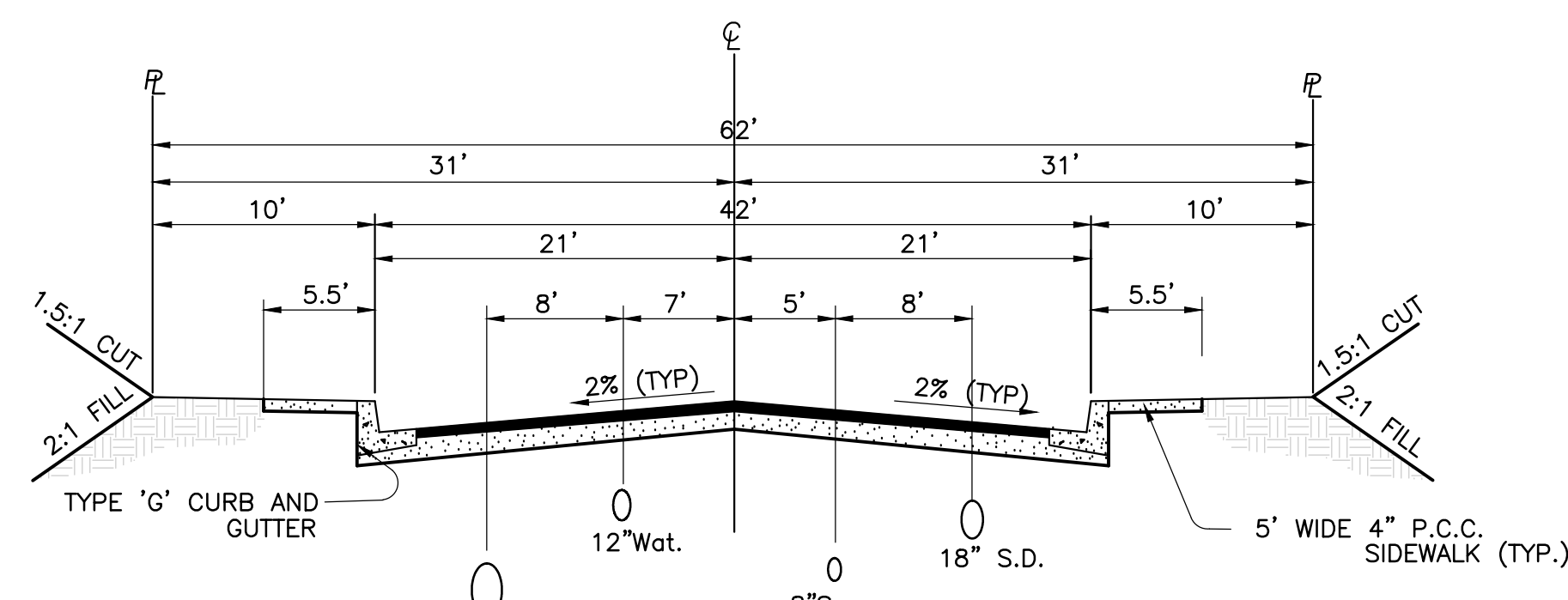

TYPICAL SECTION - VISTA AVENUE AND VISTA VERDE DRIVE
NO SCALE

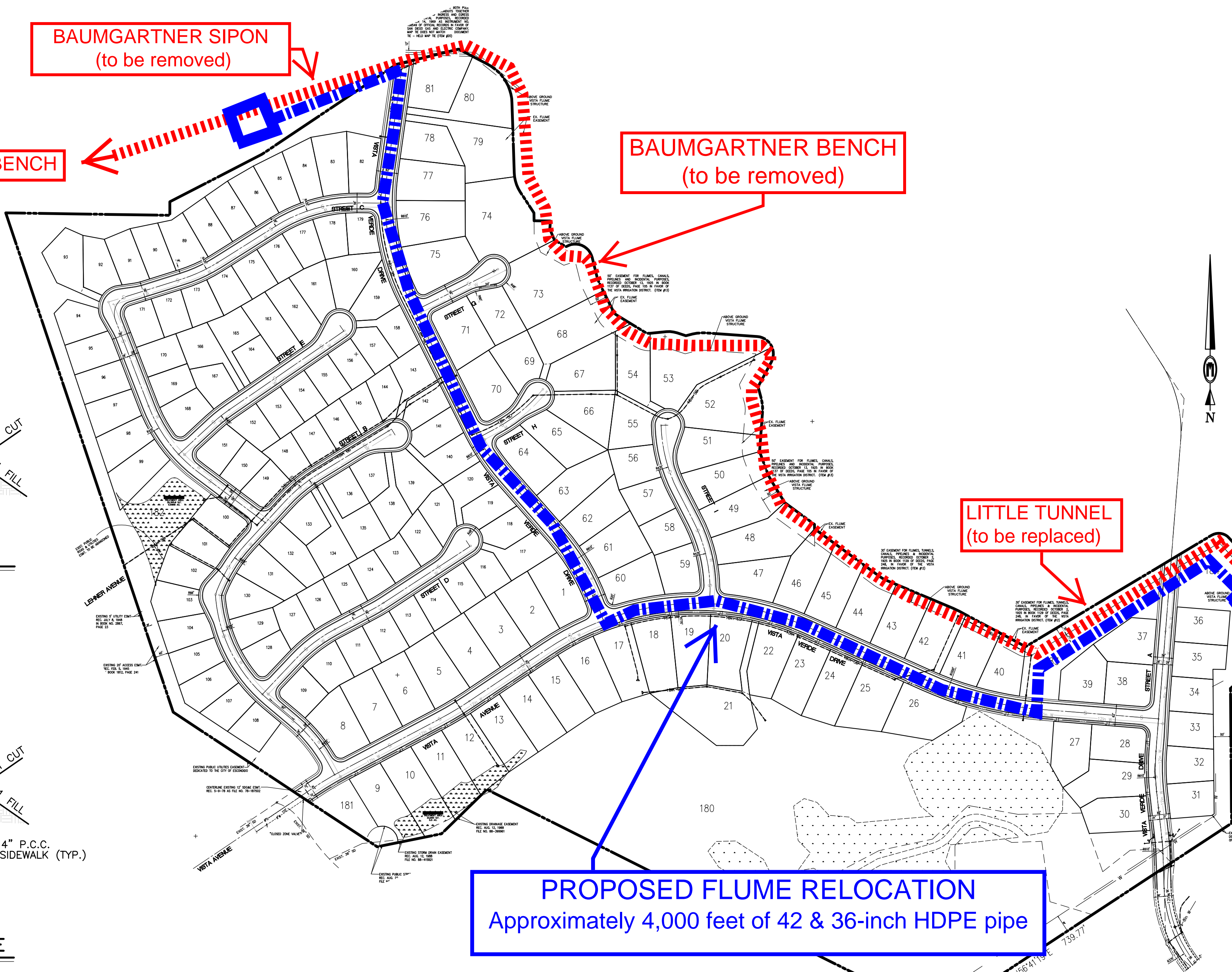

LEGEND

SYMBOL	DESCRIPTION
	MASONRY RETAINING WALL
	CUT (1 1/2:1 MAX.) FILL (2:1 MAX.)
	CONCRETE BROWDITCH
	FINISH CONTOUR
	STORM DRAIN SYSTEM
	SEWER GRAVITY MAIN
	SEWER MANHOLES
	WATER MAIN
	FIRE HYDRANT
	DAYLIGHT
	LIMITS OF GRADING
	EXIST. WATERLINE
	EXIST. STORM DRAIN SYSTEM
	EXIST. SEWERLINE

KEY MAP

SCALE 1"=200'

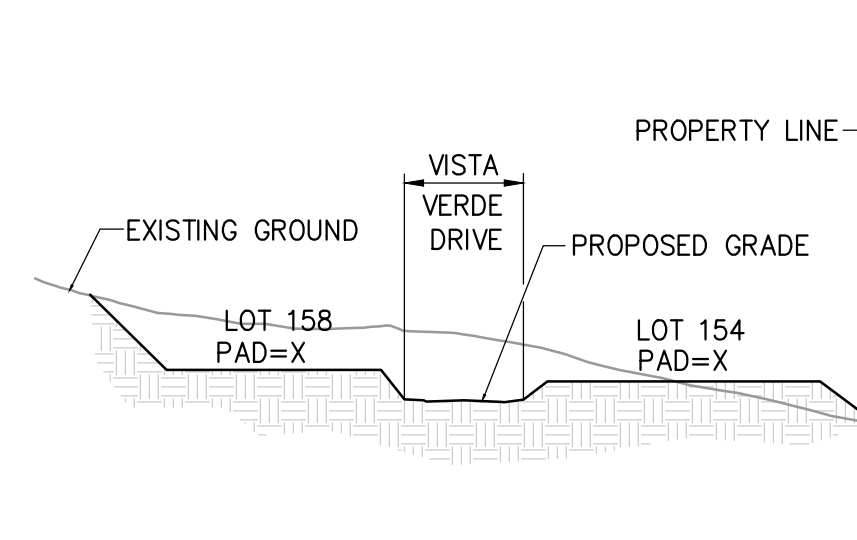

SECTION C-C

SCALE: HOR. 1"=100' VER. 1"=50'

EARTHWORK

RAW CUT VOLUME	xxxxxx C.Y.
BULKING (15.0%)	xxxxxx C.Y.
SPOILS	xxxxxx C.Y.
ADJUSTED CUT VOLUME	xxxxxx C.Y.
RAW FILL VOLUME	xxxxxx C.Y.
SHRINKAGE (3.0%)	xxxxxx C.Y.
ADJUSTED FILL VOLUME	xxxxxx C.Y.
EXPORT	xxxxxx C.Y.

* ESTIMATE ONLY.
MASSON & ASSOCIATES MAKES NO GUARANTEE THAT THESE QUANTITIES ARE ACCURATE AND COMPLETE. OWNER TO HAVE GRADING CONTRACTOR VERIFY PRIOR TO FINAL PRICING AND CONSTRUCTION.

NOTES:

- ZONING - EXISTING COUNTY A70, R-R-1, R-S-1
- GENERAL PLAN LAND USE DESIGNATION COUNTY R1, CITY E2 & R2
- MINIMUM LOT SIZE 10,000 S.F. & 20,000 S.F.
- MINIMUM AVERAGE LOT WIDTH 80'
- TOTAL LOTS 179 TOTAL UNITS 179
- SITE AREA 111.54 AC. REMAINDER PARCEL 37.75 AC.
- SITE ADDRESS 1185 LEHNER AVENUE, ESCONDIDO CA.
- CALIFORNIA COORDINATE INDEX 362-1743(x)27
- SOURCE OF TOPO SAN-LO AERIAL SURVEYS
- ASSESSOR'S PARCEL NO. 224-100-12, 57, 58, 59, AND 60
- WATER SUPPLIED BY CITY OF ESCONDIDO
- SEWAGE SUPPLIED BY CITY OF ESCONDIDO
- GAS AND ELECTRIC SUPPLIED BY SDG&E
- FIRE PROTECTION CITY OF ESCONDIDO
- SCHOOL DISTRICTS E.U.S.D. AND E.U.H.S.D.
- STREET LIGHTING PER CITY ORDINANCES, TREE PLANTING PER LANDSCAPE PLAN.
- BOUNDARY INFORMATION HAS BEEN COMPILED FROM RECORD DATA.
- ALL LOTS ARE ON A SANITARY SEWER SYSTEM. ALL UTILITIES TO BE UNDERGROUND.
- ALL IMPROVEMENTS TO BE TO THE CITY OF ESCONDIDO STANDARDS.
- ALL FILL SLOPES ARE 2:1, CUT SLOPES ARE 1.5:1 UNLESS NOTED OTHERWISE.
- ACCESS TO THE OPEN SPACE LOT WILL BE MAINTAINED AS A JOINT ACCESS D/W ALONG THE SIDE OF LOT 156

MULTIPLE FINAL MAPPING

THE SUBDIVIDER RESERVES THE RIGHT TO FILE MULTIPLE MAPS ON THIS TENTATIVE SUBDIVISION MAP IN ACCORDANCE WITH SECTION 66456.1 OF THE SUBDIVISION MAP ACT.

LEGAL DESCRIPTION

PARCEL 1, PARCEL 2, PARCEL 3, & PARCEL 4 OF PARCEL MAP NO. 17583 AND THE SE 1/4 OF THE NE 1/4 OF FRACTIONAL SECTION 3, T12S, R2W, SBB&M

OWNER/APPLICANT

SHEA HOMES, INC.
9990 MESA RIM ROAD SUITE #200
SAN DIEGO, CA 92121
PHONE: 858-526-6554

OWNER'S CERTIFICATE

I (WE) HEREBY CERTIFY THAT I (WE) AM (ARE) THE RECORD OWNER OF THE PROPERTY SHOWN ON THE TENTATIVE SUBDIVISION MAP AND THAT SAID MAP SHOWS ALL MY (OUR) CONTIGUOUS OWNERSHIP IN WHICH I (WE) HAVE ANY DEED OR TRUST INTEREST. I (WE) UNDERSTAND THAT MY (OUR) PROPERTY IS CONSIDERED CONTIGUOUS EVEN IT IS SEPARATED BY ROADS, STREETS, UTILITY EASEMENTS, OR RAILROAD RIGHTS-OF-WAY.

BY: _____ DATE: _____

ENGINEER

BY: _____ DATE: _____
MASSON & ASSOCIATES INC.
200 E. WASHINGTON AVE., STE 200
ESCONDIDO, CA. 92025
(760) 741-3570

Planning • Engineering • Surveying • Telecom
200 East Washington Ave., Suite 200
Escondido, CA 92025
P. 760.741.3570
F. 760.741.1786

MASSON & ASSOCIATES, INC.
www.masson-assoc.com



CITY PROJECT NO.
ENG. _____



CONSTRUCTION RECORD	REFERENCES	Date	By	REVISIONS	App'd	Date	BENCH MARK	SCALE	Office	Designed By	Drawn By	Checked By	Submitted	Approved	ENGINEERING SERVICES	Drawing No.	
Contractor								Horizontal	Filmed	Plans Prepared Under Supervision Of			By	Assitant City Engineer	By	Assist. Director of Public Works/Engineering	Sheet of 8
Inspector								Vertical	Traffic	ROBERT D'AMARO							
Date Completed																	



STAFF REPORT

Agenda Item: 16

Board Meeting Date: May 11, 2016
Prepared By: Phil Zamora
Reviewed By: Eldon Boone
Approved By: Roy Coox

SUBJECT: REVISIONS TO COMPENSATION SCHEDULE

RECOMMENDATION: Adopt a Resolution approving the attached changes to the 2016 Compensation Schedule for all District employees to facilitate CalPERS reporting requirements under state pension law.

PRIOR BOARD ACTION:

- 10/08/14 Adopted Resolutions No. 14-26 and No. 14-27 approving salary, benefits, and other terms and conditions of employment covering all employees for the calendar years 2015, 2016 and 2017.
- 12/17/14 Adopted Resolution No. 14-37 approving the Classification and Compensation Salary Schedule for all employees effective January 1, 2015 to facilitate CalPERS reporting requirements under state pension law.
- 12/09/15 Adopted Resolution No. 15-43 approving the Classification and Compensation Salary Schedule for all employees effective January 1, 2016 to facilitate CalPERS reporting requirements under state pension law.

FISCAL IMPACT: This Resolution to approve the attached revisions to the 2016 Compensation Schedule will memorialize the District's intent to implement changes in staffing to improve operational efficiencies, resulting in annual savings of approximately \$300,000.

SUMMARY: CalPERS retirement law requires that the governing body of all public agencies approve a salary schedule and any revisions thereto for all employees in an open public forum.

DETAILED REPORT: The California Code of Regulations (CCR) at Section 570.5 requires public agencies to make duly adopted and approved pay schedules publicly available prior to CalPERS including the compensation as a part of the members retirement benefit. CCR Section 570.5 requires that the employee pay rate be limited to the amount listed on a pay schedule that has been duly approved and adopted by the employer's governing body in accordance with the requirements of applicable public meeting laws.

The attached Resolution adds three new job titles to the Schedule that was approved in December: Water Resources Engineer, Human Resources Office Assistant, and Administrative Office Assistant. These are not new positions, but are new titles based on revised job duties that are the result of a reorganization to gain operational efficiencies and provide opportunities for internal promotional advancement. Effectively, the Water Resources Engineer position replaces the Water Resources Manager, the Human Resources Office Assistant replaces the Human Resources Specialist, and the Administrative Office Assistant replaces the Administrative Secretary.

These revisions will result in a net decrease in the District's Budget for salaries and benefits. The reorganization and reassignment of duties is anticipated to result in a new organizational structure that will enable a net reduction in staffing levels from 92 positions to 90 positions.

ATTACHMENT: Resolution Approving Revisions to the Compensation Schedule effective June 3, 2016.

RESOLUTION NO. 16-XX

RESOLUTION OF THE BOARD OF DIRECTORS OF THE
VISTA IRRIGATION DISTRICT APPROVING REVISIONS TO THE
COMPENSATION SCHEDULE

WHEREAS, the Vista Irrigation District's negotiation team completed meet and confer labor negotiations for 2015, 2016, and 2017 salaries and benefits as set forth in various Memorandum of Agreement for represented employees and a Board Resolution for unrepresented employees; and

WHEREAS, the District has previously negotiated and the Board has previously approved in each of these labor agreements certain adjustments to salary for each of the three years of the contract term; and

WHEREAS, California Code of Regulations (CCR) Section 570.5 requires public agencies to have a pay schedule duly approved and adopted by the employer's governing body in accordance with requirements of applicable public meeting laws in order for CalPERS to consider pay as "compensation earnable" for purposes of calculating a member's retirement benefit.

NOW, THEREFORE, BE IT RESOLVED that the Board of Directors of the Vista Irrigation District hereby acknowledges changes to staff positions and approves and adopts certain revisions to the Compensation Schedule as set forth in the attached "Exhibit A", incorporated herein by reference.

PASSED AND ADOPTED by the Board of Directors this 11th day of May 2016, by the following roll call vote:

AYES:
NOES:
ABSTAIN:
ABSENT:

Richard L. Vasquez, President

ATTEST:

Lisa Soto, Secretary
Board of Directors
Vista Irrigation District

VISTA IRRIGATION DISTRICT
 COMPENSATION SCHEDULE
 EFFECTIVE JUNE 3, 2016

Job Title	Range - Monthly	Non-Exempt	Exempt
Accounting Technician	\$5,702 - \$6,931	X	
Accounts Payable Clerk	\$4,277 - \$5,199	X	
Administrative Assistant	\$5,382 - \$6,542	X	
Administrative Secretary	\$4,476 - \$5,441	X	
Administrative Office Assistant (New Position)	\$4,761 - \$5,787	X	
Construction Worker <i>(New Series)</i>	\$4,277 - \$5,199	X	
Construction Worker <i>(Terminal)</i>	\$4,476 - \$5,441	X	
Customer Service Representative <i>(New Series)</i>	\$4,277 - \$5,199	X	
Customer Service Representative <i>(Terminal)</i>	\$4,476 - \$5,441	X	
Engineering Inspector	\$6,455 - \$7,846	X	
Engineering Office Assistant	\$4,476 - \$5,441	X	
Engineering Specialist II	\$6,455 - \$7,846	X	
Equipment Mechanic	\$5,146 - \$6,256	X	
Equipment Operator	\$5,146 - \$6,256	X	
Executive Assistant/Board Secretary	\$6,455 - \$7,846	X	
Facilities Locator	\$4,761 - \$5,787	X	
Facilities Office Assistant	\$4,476 - \$5,441	X	
Facilities Worker	\$5,146 - \$6,256	X	
Finance Associate	\$6,806 - \$8,272	X	
Financial Analyst	\$6,455 - \$7,846	X	
GIS Specialist	\$6,033 - \$7,333	X	
GIS Systems Associate	\$6,806 - \$8,272	X	
Heavy Equipment Operator	\$5,382 - \$6,542	X	
Human Resources Specialist	\$6,033 - \$7,333	X	
Human Resources/Safety Secretary	\$4,476 - \$5,441	X	
Human Resources Office Assistant (New Position)	\$4,761 - \$5,787	X	
Information Technology - Network Specialist	\$6,806 - \$8,272	X	
Information Technology Specialist	\$6,455 - \$7,846	X	
Inventory Control Clerk	\$4,277 - \$5,199	X	
Laborer <i>(New Series)</i>	\$3,879 - \$4,715	X	
Laborer <i>(Terminal)</i>	\$4,277 - \$5,199	X	
Laborer Trainee	\$3,695 - \$4,491	X	
Maintenance Worker	\$4,277 - \$5,199	X	
Management Analyst	\$6,806 - \$8,272	X	
Meter Reader	\$3,695 - \$4,491	X	
Meter Reader Trainee	\$3,518 - \$4,277	X	
Meter Repair Technician	\$4,476 - \$5,441	X	
Purchasing Agent	\$6,033 - \$7,333	X	
Receptionist/Cashier	\$4,277 - \$5,199	X	
Senior Accountant	\$6,806 - \$8,272	X	
Senior Construction Worker	\$6,033 - \$7,333	X	
Senior Customer Service Rep.	\$4,761 - \$5,787	X	
Senior Equipment Mechanic	\$6,033 - \$7,333	X	
Senior Facilities Worker	\$6,033 - \$7,333	X	
System Controls Technician I	\$6,033 - \$7,333	X	

Job Title	Range - Monthly	Non-Exempt	Exempt
System Controls Technician II	\$6,455 - \$7,846	X	
System Controls Technician III	\$6,806 - \$8,272	X	
System Operator I	\$5,382 - \$6,542	X	
System Operator II	\$5,702 - \$6,931	X	
Water Conservation Specialist I	\$6,033 - \$7,333	X	
Water Quality Operator I	\$5,382 - \$6,542	X	
Water Quality Operator II	\$5,702 - \$6,931	X	
Water Quality Operator III	\$6,033 - \$7,333	X	
Water Resources Aide	\$4,761 - \$5,787	X	
Water Resources Office Assistant	\$4,476 - \$5,441	X	
Welder/Equipment Operator	\$5,702 - \$6,931	X	
Welder Helper	\$5,146 - \$6,256	X	
Welder I	\$5,382 - \$6,542	X	
Welder II	\$5,702 - \$6,931	X	
Welder III	\$6,033 - \$7,333	X	
Administrative Services Manager	\$9,533 - \$12,776		X
Assistant General Manager	\$12,131 - \$16,257		X
Construction Supervisor	\$7,163 - \$9,600		X
Customer Service Manager	\$8,995 - \$12,054		X
Customer Service Supervisor	\$5,702 - \$7,641		X
Director of Engineering	\$12,131 - \$16,257		X
Director of Water Resources	\$11,844 - \$15,872		X
Engineering Project Manager	\$9,533 - \$12,776		X
Engineering Services Manager	\$8,995 - \$12,054		X
Facilities Supervisor	\$7,163 - \$9,600		X
Finance Manager	\$9,533 - \$12,776		X
General Manager(New Compensation)	\$18,125 - \$18,125		X
Human Resources Manager	\$9,533 - \$12,776		X
Information Technology Supervisor	\$7,163 - \$9,600		X
Operations and Field Services Manager	\$9,976 - \$13,369		X
Safety/Risk Manager	\$8,995 - \$12,054		X
System Controls Supervisor	\$7,163 - \$9,600		X
Water Distribution Supervisor	\$7,163 - \$9,600		X
Water Resources Manager	\$8,995 - \$12,054		X
Water Resources Engineer(New Position)	\$8,163 - \$10,940		X
Water Resources Supervisor	\$5,702 - \$7,641		X



Agenda Item: 17

STAFF REPORT

Board Meeting Date: May 11, 2016
Prepared By: Roy Coox

SUBJECT: MATTERS PERTAINING TO THE ACTIVITIES OF THE SAN DIEGO COUNTY WATER AUTHORITY

SUMMARY: Informational report by staff and directors concerning the San Diego County Water Authority. No action will be required.



STAFF REPORT

Agenda Item: 18.A

Board Meeting Date: May 11, 2016
Prepared By: Lisa Soto
Approved By: Roy Coox

SUBJECT: REPORTS ON MEETINGS AND EVENTS ATTENDED BY DIRECTORS

SUMMARY: Directors will present brief reports on meetings and events attended since the last Board meeting.



STAFF REPORT

Board Meeting Date: May 11, 2016
Prepared By: Marian Schmidt
Approved By: Roy Coox

SUBJECT: SCHEDULE OF UPCOMING MEETINGS AND EVENTS AND DIRECTORS ATTENDING

SUMMARY: The following is a listing of upcoming meetings and events. Requests to attend any of the following events should be made during this agenda item.

	SCHEDULE OF UPCOMING MEETINGS AND EVENTS	ATTENDEES
1	Communication Protocols for Board Members/Staff Webinar (CSDA) <i>May 12, 2016 – 10:00 a.m. – 12:00 p.m.</i> <i>Registration deadline: 5/5/16</i>	
2	CSDA SD Chapter Video Contest Awards Ceremony <i>May 12, 2016 – 6:00 p.m. – Helix Water District Board Room</i> <i>Please RSVP</i>	
3 *	Council of Water Utilities Meeting <i>May 17, 2016, 7:00 a.m., Stoneridge Country Club, Poway</i> <i>Reservation deadline: 5/12/16</i>	Dorey (R)
4	Legislative Days (CSDA) <i>May 17-18, 2016 – Sacramento Convention Center, Sacramento</i> <i>Registration deadline: 5/10/16</i>	MacKenzie (R)
5 *	CSDA Quarterly Dinner Meeting <i>May 19, 2016 – 6:00-9:00 p.m. – The Butcher Shop Steakhouse, Kearny Mesa</i> <i>Reservation deadline: 5/12/16</i>	MacKenzie (R)
6	San Diego Tour – Carlsbad Desalination Plant (Water Education Foundation) <i>May 19-20, 2016 – Start 7:00 a.m. on 5/19 – end at 6:00 p.m. on 5/20</i> <i>Registration deadline: 4/19/16</i>	
7	Colorado River Aqueduct System Tour (SDCWA) <i>May 21-22, 2016 – Meets at SDCWA</i> <i>Reservation deadline: First come first serve basis</i>	
8	Communication Protocols for Board Members/Staff Webinar (CSDA) <i>May 26, 2016 – 10:00 a.m. – 12:00 p.m.</i> <i>Registration deadline: 5/19/16</i>	
9	AB 1825 Sexual Harassment Prevention Training Webinar (CSDA) <i>June 1, 2016 – 10:00 a.m. – 12:00 p.m.</i> <i>Registration deadline: 5/26/16</i>	
10	California Water Summit <i>June 1-3, 2016 – The Westin Sacramento</i> <i>Registration deadline: None</i>	
11	Vista Historical Society Annual Meeting and Hall of Fame Induction <i>June 4, 2016, 11:30 a.m., Vista Valley Country Club, 29354 Vista Valley Drive, Vista</i> <i>Registration deadline: 5/27/16</i>	Dorey Vásquez
12	California Water Law & Policy Conference <i>June 13-14, 2016 – Hotel Nikko, San Francisco</i> <i>Registration deadline: None</i>	
13	Bay Delta Tour (Water Education Foundation) <i>June 15-17, 2016 – Tour starts at Sacramento Airport</i> <i>Registration deadline: 5/15/16</i>	

14 *	Council of Water Utilities Meeting <i>June 21, 2016, 7:00 a.m., Stoneridge Country Club, Poway</i> <i>Reservation deadline: 6/16/16</i>	
15	LAFCO 101 for Special Districts Webinar (CSDA) <i>June 29, 2016 – 10:00 a.m. – 11:30 a.m.</i> <i>Registration deadline: 6/23/16</i>	
16	Special District Leadership Academy Conference #2 (CSDA) <i>July 10-13, 2016 – Embassy Suites Napa Valley, Napa</i> <i>Registration deadline: 7/1/16</i>	
17 *	Council of Water Utilities Meeting <i>July 19, 2016, 7:00 a.m., Stoneridge Country Club, Poway</i> <i>Reservation deadline: 7/14/16</i>	
18	Legislative Round-Up Webinar (CSDA) <i>Aug. 11, 2016 – 10:00 a.m. – 12:00 p.m.</i> <i>Registration deadline: 8/4/16</i>	
19 *	Council of Water Utilities Meeting <i>Aug. 16, 2016, 7:00 a.m., Stoneridge Country Club, Poway</i> <i>Reservation deadline: 8/11/16</i>	
20 *	CSDA Quarterly Dinner Meeting <i>Aug. 18, 2016 – 6:00-9:00 p.m. – The Butcher Shop Steakhouse, Kearny Mesa</i> <i>Reservation deadline: 8/11/16</i>	
21	Urban Water Institute's Annual Water Conference <i>Aug. 24-26, 2016 – Hilton San Diego</i> <i>Registration deadline: 8/10/16</i>	
22	The Who, What, Where, When, Why and How of Public Engagement (CSDA) <i>Sept. 7, 2016 – CSDA Training Center, Sacramento</i> <i>Registration deadline: 9/1/16</i>	
23 *	Council of Water Utilities Meeting <i>Sept. 20, 2016, 7:00 a.m., Stoneridge Country Club, Poway</i> <i>Reservation deadline: 9/15/16</i>	
24	CEQA – California Environmental Quality Act (CSDA) <i>Sept. 21, 2016 – CSDA Training Center, Sacramento</i> <i>Registration deadline: 9/15/16</i>	
25	CSDA Annual Conference <i>Oct. 10-13, 2016 – Sheraton San Diego Hotel</i> <i>Registration deadline: 9/9/16</i>	MacKenzie (H)
26 *	Council of Water Utilities Meeting <i>Oct. 18, 2016, 7:00 a.m., Stoneridge Country Club, Poway</i> <i>Reservation deadline: 10/13/16</i>	
27	Northern California Tour (Water Education Foundation) <i>Oct. 19-21, 2016 – Tour starts at Sacramento Airport</i> <i>Registration deadline: 9/19/16</i>	
28	ACWA Region 10 Program <i>Oct. 28, 2016 – Vista Irrigation District</i>	
29	San Joaquin Restoration Tour (Water Education Foundation) <i>Nov. 2-3, 2016 – Tour starts at Sacramento Airport</i> <i>Registration deadline: 10/2/16</i>	
30	Ethics AB 1234 Compliance Training Webinar (CSDA) <i>Nov. 8, 2016 – 10:00 a.m. – 12:00 p.m.</i> <i>Registration deadline: 11/3/16</i>	
31 *	Council of Water Utilities Meeting <i>Nov. 15, 2016, 7:00 a.m., Stoneridge Country Club, Poway</i> <i>Reservation deadline: 11/10/16</i>	
32 *	CSDA Quarterly Dinner Meeting <i>Nov. 17, 2016 – 6:00-9:00 p.m. – The Butcher Shop Steakhouse, Kearny Mesa</i> <i>Reservation deadline: 11/10/16</i>	

33	ACWA Fall Conference <i>Nov. 29-Dec. 2, 2016 – Anaheim Marriott Hotel</i> <i>Registration deadline: TBD</i>	
34	Colorado River Water Users Association Annual Conference <i>Dec. 7-9, 2016 – Caesar's Palace, Las Vegas</i> <i>Registration deadline: TBD</i>	
35 *	Council of Water Utilities Meeting <i>Dec. 20, 2016, 7:00 a.m., Stoneridge Country Club, Poway</i> <i>Reservation deadline: 12/15/16</i>	

* Non-per diem meeting except when serving as an officer of the organization

The following abbreviations indicate arrangements that have been made by staff:

A=Airline; **R**=Registration; **C**=Car; **H**=Hotel; **T**=Tentative



STAFF REPORT

Board Meeting Date: May 11, 2016
Prepared By: Lisa Soto

SUBJECT: ITEMS FOR FUTURE AGENDAS AND/OR PRESS RELEASES

SUMMARY: This item is placed on the agenda to enable the Board to identify and schedule future items for discussion at upcoming Board meetings and/or identify press release opportunities.

Staff-generated list of tentative items for future agendas:

- Update on status of Warner-Carrillo Ranch House Barn
- Love Tap! tap water promotion update
- Groundwater study update
- Development of policy on sale/lease of District properties